

# DI

## SECTION

# DRIVER INFORMATION SYSTEM

## CONTENTS

|  |    |   |    |    |
|--|----|---|----|----|
| <b>SERVICE INFORMATION</b> .....   | 3  | CONSULT-III Function (METER/M&A) .....  | 27 | A  |
| <b>DTC INDEX</b> .....   | 3  | Power Supply and Ground Circuit Inspection .....                              | 29 | B  |
| U1000 .....  | 3  | DTC [U1000] CAN Communication Circuit .....                                   | 30 | C  |
| B2202 - B2205 .....  | 3  | DTC [B2202] Meter Communication Circuit .....                                 | 30 | D  |
| <b>PRECAUTION</b> .....  | 4  | DTC [B2205] Vehicle Speed Circuit .....                                       | 33 | E  |
| Precaution for Supplemental Restraint System<br>(SRS) "AIR BAG" and "SEAT BELT PRE-TEN-<br>SIONER" ..... | 4  | Removal and Installation of Unified Meter and A/C<br>Amp .....                | 33 | F  |
| <b>PREPARATION</b> .....   | 5  | <b>WARNING LAMPS</b> .....  | 34 | G  |
| Commercial Service Tool .....  | 5  | System Description .....  | 34 | H  |
| <b>COMBINATION METERS</b> .....  | 6  | Component Parts and Harness Connector Loca-<br>tion .....                     | 35 | I  |
| System Description .....   | 6  | Schematic .....   | 36 | J  |
| Arrangement of Combination Meter .....   | 11 | Wiring Diagram - WARN - .....   | 37 | DI |
| Component Parts Location .....   | 12 | Oil Pressure Warning Lamp Stays Off (Ignition<br>Switch ON) .....             | 46 | L  |
| Internal Circuit .....   | 13 | Oil Pressure Warning Lamp Does Not Turn Off<br>(Oil Pressure Is Normal) ..... | 47 | M  |
| Wiring Diagram - METER - .....   | 14 | Electrical Component Inspection .....   | 48 | N  |
| Terminal and Reference Value for Combination<br>Meter .....  | 16 | <b>A/T INDICATOR</b> .....  | 50 | O  |
| Terminal and Reference Value for Unified Meter<br>and A/C Amp .....                                      | 17 | System Description .....  | 50 | P  |
| Self-Diagnosis Mode of Combination Meter .....   | 17 | Wiring Diagram - AT/IND - .....   | 51 |    |
| CONSULT-III Function (METER/M&A) .....   | 18 | A/T Indicator Is Malfunction .....  | 52 |    |
| Trouble Diagnosis .....  | 18 | <b>WARNING CHIME</b> .....  | 54 |    |
| Symptom Chart .....  | 19 | System Description .....  | 54 |    |
| Power Supply and Ground Circuit Inspection .....   | 19 | Component Parts and Harness Connector Loca-<br>tion .....                     | 56 |    |
| Vehicle Speed Signal Inspection .....  | 20 | Schematic .....   | 57 |    |
| Engine Speed Signal Inspection .....   | 21 | Wiring Diagram - CHIME - .....  | 58 |    |
| Engine Coolant Temperature Signal Inspection .....   | 22 | Terminal and Reference Value for Combination<br>Meter .....                   | 61 |    |
| Fuel Level Sensor Signal Inspection .....  | 22 | Terminal and Reference Value for Unified Meter<br>and A/C Amp .....           | 61 |    |
| Electrical Component Inspection .....  | 24 | Terminal and Reference Value for BCM .....                                    | 62 |    |
| Removal and Installation of Combination Meter .....  | 25 | CONSULT-III Function (BCM) .....  | 63 |    |
| Disassembly and Assembly of Combination Meter<br>.....   | 25 | CONSULT-III Function (METER/M&A) .....  | 63 |    |
| <b>UNIFIED METER AND A/C AMP</b> .....   | 26 | Trouble Diagnosis .....   | 64 |    |
| System Description .....   | 26 | Meter Buzzer Circuit Inspection .....   | 64 |    |
| Schematic .....  | 27 | Lighting Switch Signal Inspection .....                                       | 65 |    |

|   |           |   |           |
|---|-----------|---|-----------|
| Front Door Switch (Driver Side) Signal Inspection.. | 65        | Zone Variation Setting Procedure .....    | 72        |
| Seat Belt Buckle Switch Signal Inspection .....     | 66        | Calibration Procedure .....               | 72        |
| Parking Brake Switch Signal Inspection .....        | 67        | Wiring Diagram - COMPAS - .....           | 74        |
| Electrical Component Inspection .....               | 68        | Removal and Installation of Compass ..... | 74        |
| <b>LANE DEPARTURE WARNING SYSTEM .....</b>          | <b>70</b> | <b>CLOCK .....</b>                        | <b>75</b> |
| Description .....                                   | 70        | Wiring Diagram - CLOCK - .....            | 75        |
| <b>COMPASS .....</b>                                | <b>71</b> | Removal and Installation of Clock .....   | 75        |
| Precaution for Compass .....                        | 71        | <b>CAN COMMUNICATION .....</b>            | <b>77</b> |
| System Description .....                            | 71        | System Description .....                  | 77        |
| Troubleshooting .....                               | 71        | CAN Communication Unit .....              | 77        |

# DTC INDEX

< SERVICE INFORMATION >

## SERVICE INFORMATION

### DTC INDEX

U1000

INFOID:000000003024039

| DTC   | Items (CONSULT screen terms) | Reference  |
|-------|------------------------------|--|
| U1000 | CAN COMM CIRCUIT             | <a href="#">DI-30, "DTC [U1000] CAN Communication Circuit"</a> |

B2202 - B2205

INFOID:000000003024040

| DTC   | Items (CONSULT screen terms) | Reference  |
|-------|------------------------------|--|
| B2202 | METER COMM CIRC              | <a href="#">DI-30, "DTC [B2202] Meter Communication Circuit"</a> |
| B2205 | VEHICLE SPEED CIRC           | <a href="#">DI-33, "DTC [B2205] Vehicle Speed Circuit"</a>       |

A  
B  
C  
D  
E  
F  
G  
H  
I  
J  
DI  
L  
M  
N  
O  
P



## PRECAUTION

< SERVICE INFORMATION >

---

### PRECAUTION

#### Precaution for Supplemental Restraint System (SRS) "AIR BAG" and "SEAT BELT PRE-TENSIONER"

INFOID:000000003443964

The Supplemental Restraint System such as "AIR BAG" and "SEAT BELT PRE-TENSIONER", used along with a front seat belt, helps to reduce the risk or severity of injury to the driver and front passenger for certain types of collision. This system includes seat belt switch inputs and dual stage front air bag modules. The SRS system uses the seat belt switches to determine the front air bag deployment, and may only deploy one front air bag, depending on the severity of a collision and whether the front occupants are belted or unbelted.

Information necessary to service the system safely is included in the "SUPPLEMENTAL RESTRAINT SYSTEM" and "SEAT BELTS" of this Service Manual.

#### **WARNING:**

- To avoid rendering the SRS inoperative, which could increase the risk of personal injury or death in the event of a collision which would result in air bag inflation, all maintenance must be performed by an authorized NISSAN/INFINITI dealer.
- Improper maintenance, including incorrect removal and installation of the SRS, can lead to personal injury caused by unintentional activation of the system. For removal of Spiral Cable and Air Bag Module, see the "SUPPLEMENTAL RESTRAINT SYSTEM".
- Do not use electrical test equipment on any circuit related to the SRS unless instructed to in this Service Manual. SRS wiring harnesses can be identified by yellow and/or orange harnesses or harness connectors.

#### PRECAUTIONS WHEN USING POWER TOOLS (AIR OR ELECTRIC) AND HAMMERS

#### **WARNING:**

- When working near the Air Bag Diagnosis Sensor Unit or other Air Bag System sensors with the ignition ON or engine running, DO NOT use air or electric power tools or strike near the sensor(s) with a hammer. Heavy vibration could activate the sensor(s) and deploy the air bag(s), possibly causing serious injury.
- When using air or electric power tools or hammers, always switch the ignition OFF, disconnect the battery, and wait at least 3 minutes before performing any service.

# PREPARATION

< SERVICE INFORMATION >

## PREPARATION

### Commercial Service Tool

INFOID:000000002956874

| Tool name  | Description   |
|--|---|
| <p data-bbox="159 352 267 378">Power tool</p>  <p data-bbox="776 571 844 588">PIIB1407E</p> | <p data-bbox="1010 352 1344 378">Loosening bolts, nuts and screws</p> |

A

B

C

D

E

F

G

H

I

J

**DI**

L

M

N

O

P

# COMBINATION METERS

< SERVICE INFORMATION >

## COMBINATION METERS

### System Description

INFOID:00000002956875

#### UNIFIED METER CONTROL UNIT

- Speedometer, odo/trip meter, tachometer, fuel gauge and water temperature gauge are controlled by the unified meter control unit, which is built into the combination meter. Unified meter control unit receives signals from unified meter and A/C amp.
- Warning lamp and indicator lamp of combination meter are controlled by signals drawn from the unified meter and A/C amp.
- Digital meter is adopted for odo/trip meter.

#### NOTE:

The record of the odo meter is kept even if the battery cable is disconnected. The record of the trip meter is erased when the battery cable is disconnected.

- Dot matrix LCD is adopted to display "push engine starter", "A/T position" and "ICC system\*".
- Odo/trip meter and dot matrix LCD segments can be checked in self-diagnosis mode.
- Meters/gauges can be checked in self-diagnosis mode.

\*: With ICC system

#### UNIFIED METER AND A/C AMP.

Refer to [DI-26. "System Description"](#) in "UNIFIED METER AND A/C AMP".

#### POWER SUPPLY AND GROUND CIRCUIT

Power is supplied at all times

- through 10A fuse [No. 21, located in the fuse block (J/B)]
- to combination meter terminal 23,
- through 10A fuse [No. 19, located in the fuse block (J/B)]
- to unified meter and A/C amp. terminal 54.

With the ignition switch in the ACC or ON position, power is supplied

- through 10A fuse [No. 6, located in the fuse block (J/B)],
- to combination meter terminal 2, and
- to unified meter and A/C amp. terminal 41.

With the ignition switch in the ON or START position, power is supplied

- through 10A fuse [No. 14, located in the fuse block (J/B)]
- to combination meter terminal 12,
- through 10A fuse [No. 12, located in the fuse block (J/B)]
- to unified meter and A/C amp. terminal 53.

Ground is supplied

- to combination meter terminals 9, 10 and 11
- to unified meter and A/C amp. terminals 55 and 71
- through grounds M16 and M70.

#### SPEEDOMETER

The speedometer indicates the vehicle speed.

- The ABS actuator and electric unit (control unit) converts the pulse signal provided by the wheel sensor to a vehicle speed signal and transmits it to the unified meter and A/C amp. with CAN communication line.
- The unified meter and A/C amp. receives the vehicle speed signal from the ABS actuator and electric unit (control unit) with CAN communication line and transmits it to the combination meter by means of communication line.
- The combination meter indicates the vehicle speed according to the vehicle speed signal received from the unified meter and A/C amp. by means of communication line.

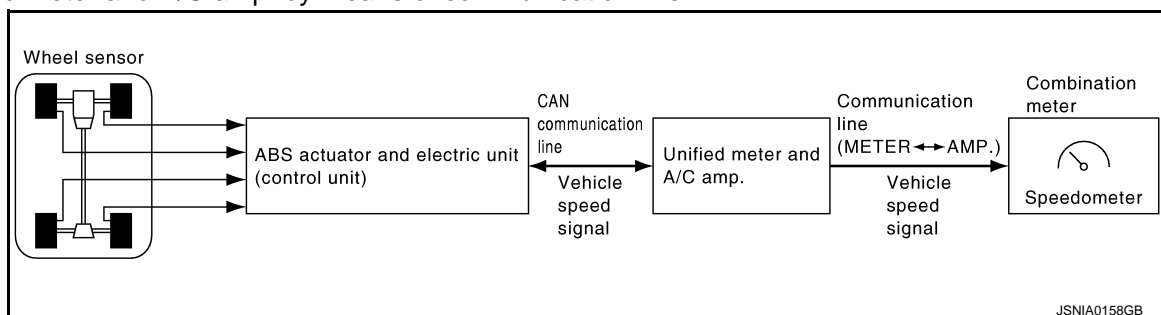

JSNIA0158GB

# COMBINATION METERS

## < SERVICE INFORMATION >

### TACHOMETER

The tachometer indicates engine speed in revolutions per minute (rpm).

- The ECM converses the pulse signal provided by the crankshaft position sensor to an engine speed signal and transmits it to unified meter and A/C amp. with CAN communication.
- The unified meter and A/C amp. transmits engine speed signal to combination meter with communication line.
- The unified meter and A/C amp. receives the engine speed signal from the ECM with CAN communication line and transmits it to the combination meter by means of communication line.
- Combination meter converses engine speed signal to the angle signal, and commands to tachometer.

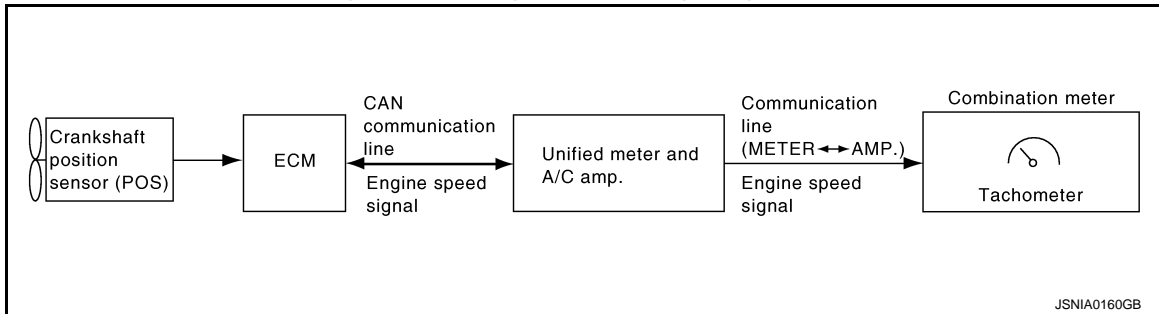

### WATER TEMPERATURE GAUGE

The water temperature gauge indicates the engine coolant temperature.

- The ECM converses a signal from engine coolant temperature sensor to engine coolant temperature signal, and transmits to unified meter and A/C amp. with CAN communication.
- The unified meter and A/C amp. transmits engine coolant temperature signal to the combination meter with communication line.
- The combination meter converses engine coolant temperature signal to the angle signal, and commands to water temperature gauge.

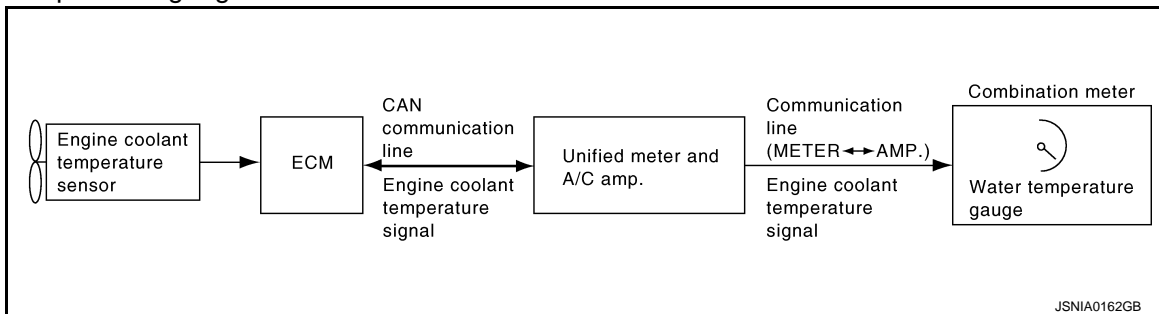

### FUEL GAUGE

The fuel gauge indicates the approximate fuel level in the fuel tank.

The fuel gauge is regulated by a variable ground signal supplied

- from unified meter and A/C amp. terminal 58
- through the fuel level sensor unit and fuel pump (main) terminals 5 and 2, and
- through the fuel level sensor unit (sub) terminals 2 and 1
- to unified meter and A/C amp. terminal 42.

Unified meter and A/C amp. provides a fuel level signal to combination meter for fuel gauge with communication line between unified meter and A/C amp. and combination meter.

### ODO/TRIP METER

- ABS actuator and electric unit (control unit) converses a pulse signal from wheel sensor to vehicle speed signal, and transmits vehicle speed signal to unified meter and A/C amp. with CAN communication.
- Unified meter and A/C amp. converses vehicle speed signal to 8 pulse signal, and transmits to combination meter.
- Combination meter processes the 8 pulse signal and the memory signals from the meter memory circuit. Then the mileage is displayed.

How to Change The Display For Odo/trip Meter

# COMBINATION METERS

## < SERVICE INFORMATION >

Operating the odo/trip meter switch allows switching the mode in the following order.

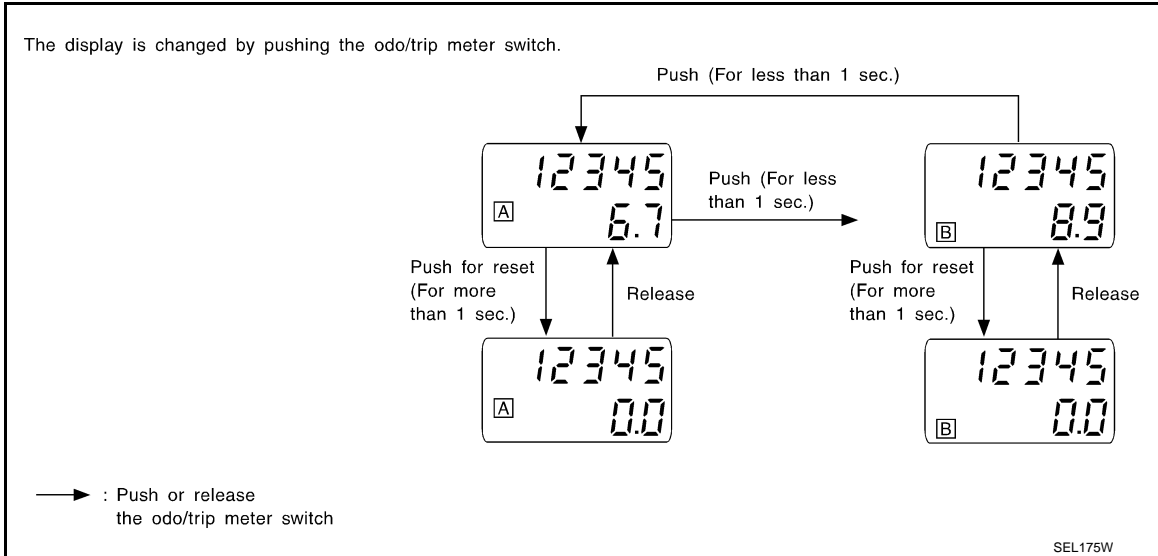

- The odo/trip meter display switching and trip display resetting can be identified by the time from pressing the odo/trip meter switch (1) to releasing it.
- When resetting with “trip A” displayed, only “trip A” display is reset. (The same way for “trip B”.)

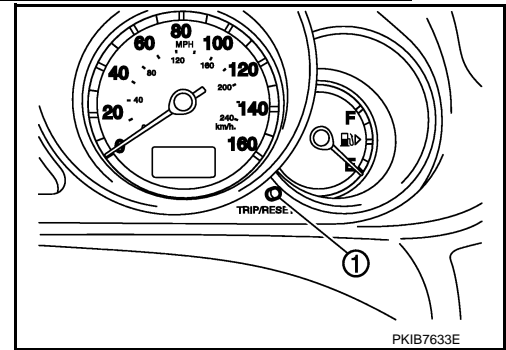

## METER ILLUMINATION CONTROL

- Meter illumination\* is controlled by the unified meter control unit.
- Ring illumination under normal operation and engine start excitement function can be turned ON/OFF with pressing meter illumination control switch for more than 1 second.

\*: Illumination for ring, meter face, pointer, dot matrix LCD and odo/trip meter

### Daytime Mode

Meter illumination is adjusted to 5 steps by meter illumination control switch (1) in daytime mode.

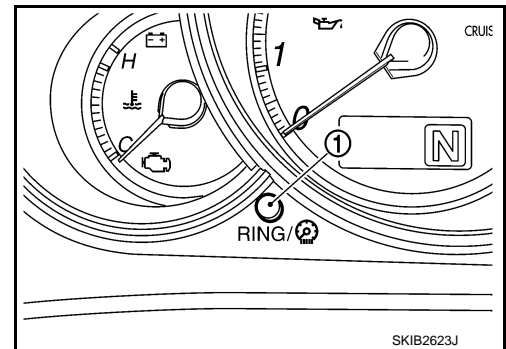

### Nighttime Mode

- Combination meter is transferred to nighttime mode with position light request signal from BCM with CAN communication.



# COMBINATION METERS

## < SERVICE INFORMATION >

- Meter illumination is adjusted to 16 steps by illumination control switch (1) in nighttime. Refer to [LT-253, "System Description"](#).

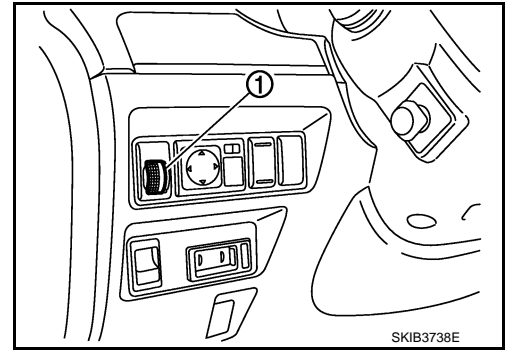

### Driver Welcome Function

Ring illumination gradually turns ON when a driver gets in the vehicle with Intelligent Key and closes the driver side door.

#### NOTE:

Ring illumination gradually turns OFF when not turning the ignition switch ON at a certain period of time.

### Engine Start Excitement Function

Combination meter detects the engine start when input engine speed signal at first. Pointers of speed meter and tachometer sweep and ring illumination gradually turns ON when combination meter detects the engine start. Then, combination meter starts the normal control.

#### NOTE:

- Water temperature gauge and fuel gauge do not function.
- Engine start excitement function can be turned ON/OFF with pressing meter illumination control switch for more than 1 second.

### FAIL-SAFE

Combination meter performs fail-safe operation when unified meter and A/C amp. communication is malfunction.

Solution for communication error between the unified meter and A/C amp. and combination meter

| Function                |                     | Specifications   |
|-------------------------|---------------------|--|
| Speedometer             |                     | Reset to zero by suspending communication.               |
| Tachometer              |                     |  |
| Fuel gauge              |                     |  |
| Water temperature gauge |                     |  |
| Illumination control    | Meter illumination  | When suspending communication, change to nighttime mode. |
|                         | Push engine starter |  |
| Dot matrix LCD          | A/T position        | The display turns off by suspending communication.       |
|                         | ICC system          |  |
| Buzzer                  |                     | The buzzer turns off by suspending communication.        |

# COMBINATION METERS

## < SERVICE INFORMATION >

|                             | Function                       | Specifications                                  |
|-----------------------------|--------------------------------|---|
| Warning lamp/indicator lamp | ABS warning lamp               | The lamp turns on by suspending communication.  |
|                             | Brake warning lamp             |   |
|                             | CRUISE warning lamp            |   |
|                             | VDC OFF indicator lamp         |   |
|                             | SLIP indicator lamp            |   |
|                             | A/T CHECK warning lamp         | The lamp turns off by suspending communication. |
|                             | AWD warning lamp               |   |
|                             | Oil pressure warning lamp      |   |
|                             | Door warning lamp              |   |
|                             | Malfunction indicator lamp     |   |
|                             | CRUISE indicator lamp          |   |
|                             | SET indicator lamp             |   |
|                             | Low tire pressure warning lamp |   |
|                             | AFS OFF indicator lamp         |   |
|                             | Front fog lamp indicator lamp  |   |
|                             | Tail lamp indicator lamp       |   |
|                             | High beam indicator lamp       |   |
|                             | Turn signal indicator lamp     |   |
|                             | Key warning lamp               |   |

# COMBINATION METERS

< SERVICE INFORMATION >

## Arrangement of Combination Meter

INFOID:000000002956876

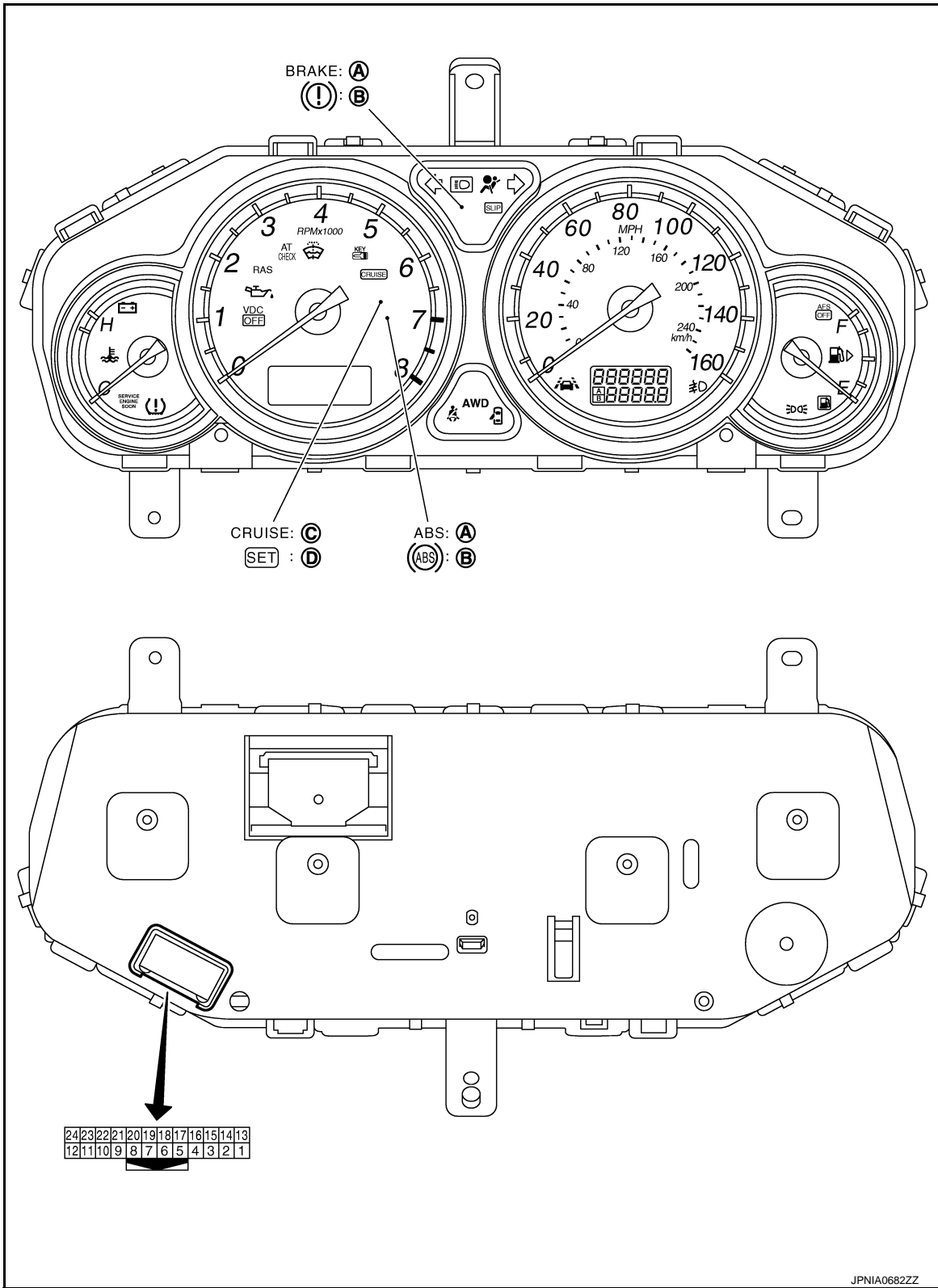

A  
B  
C  
D  
E  
F  
G  
H  
I  
J  
K  
L  
M  
N  
O  
P

DI

A. For U.S.A.  
D. Without ICC

B. For Canada

C. With ICC

JPNIA0682ZZ

# COMBINATION METERS

< SERVICE INFORMATION >

## Component Parts Location

INFOID:00000002956877

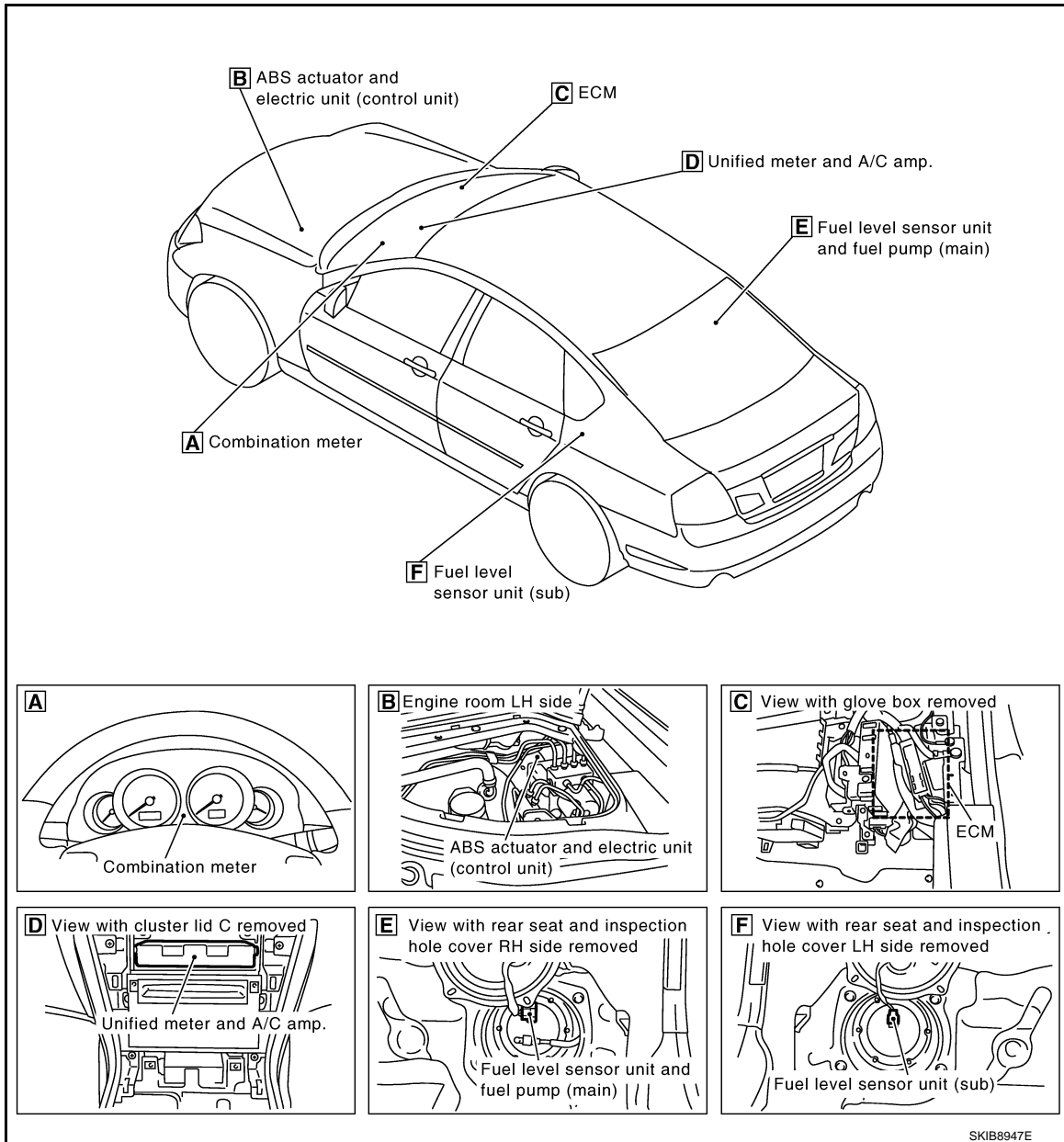

# COMBINATION METERS

< SERVICE INFORMATION >

## Internal Circuit

INFOID:00000002956878

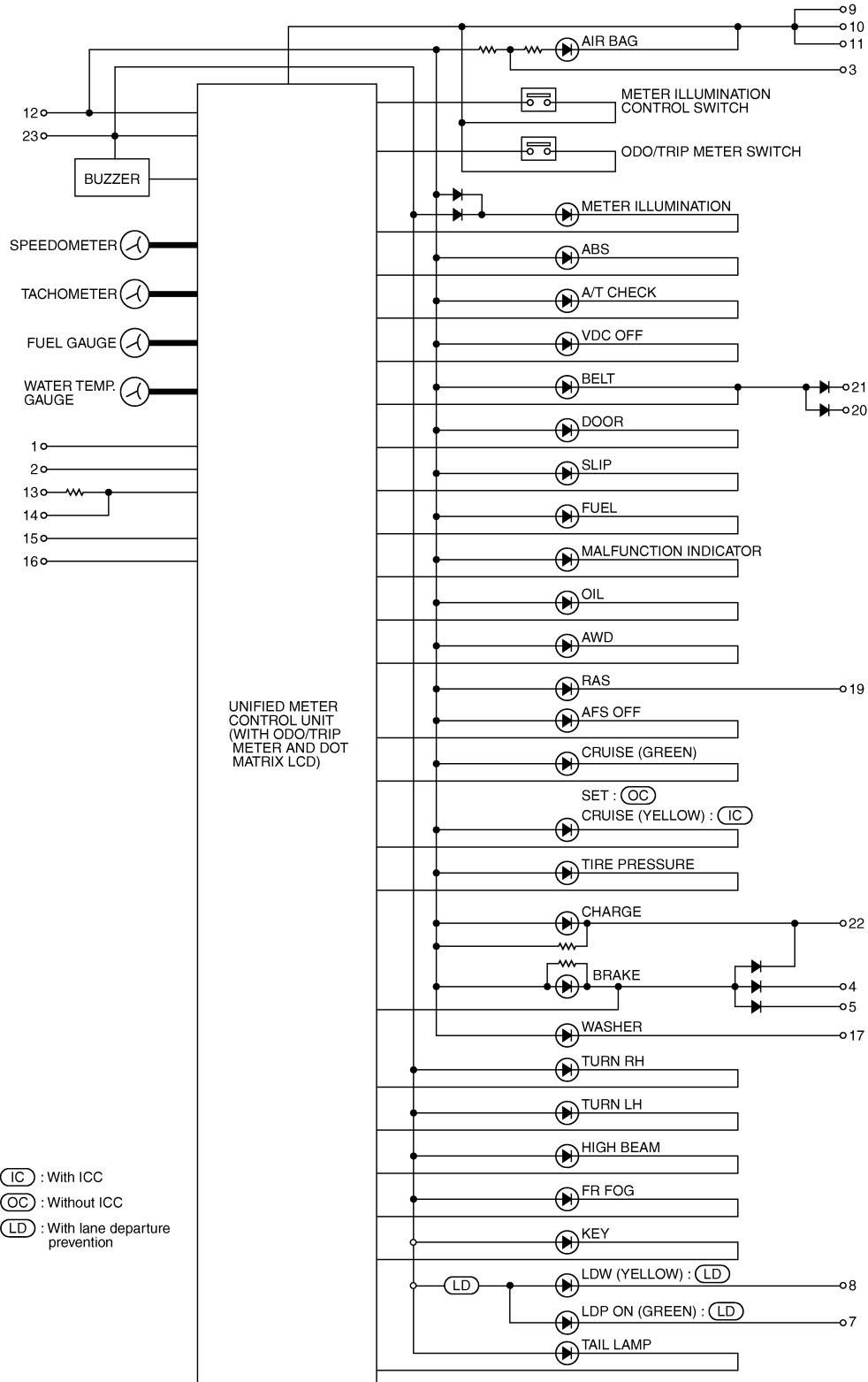

TKWT6852E

A  
B  
C  
D  
E  
F  
G  
H  
I  
J  
DI  
L  
M  
N  
O  
P

# COMBINATION METERS

< SERVICE INFORMATION >

## Wiring Diagram - METER -

INFOID:00000002956879

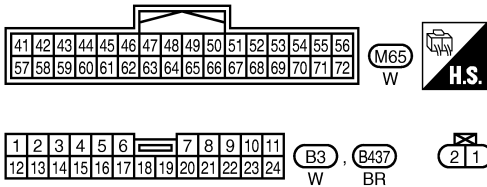
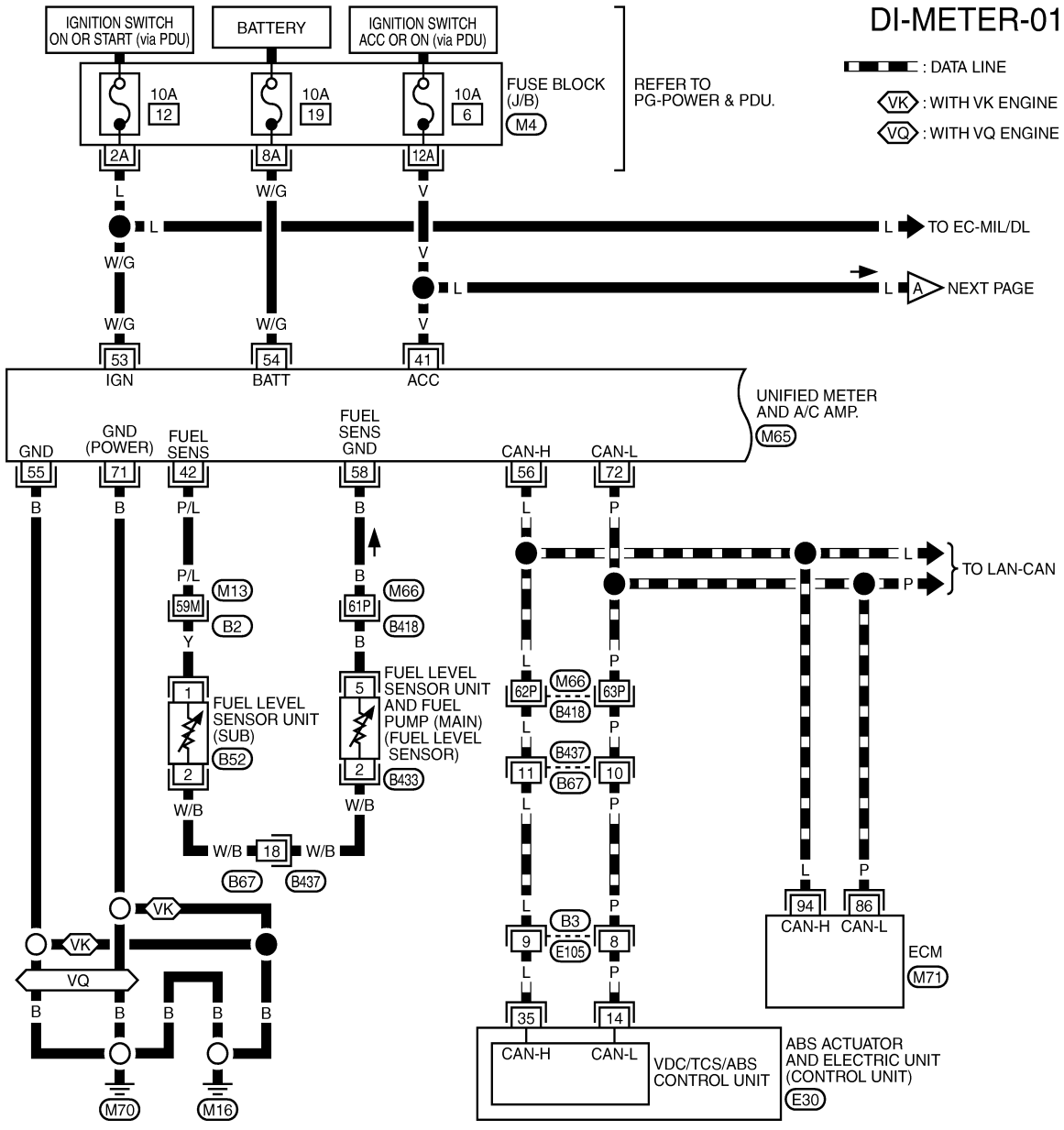

REFER TO THE FOLLOWING.  
 (B2), (B418) - SUPER MULTIPLE JUNCTION (SMJ)  
 (M4) - FUSE BLOCK - JUNCTION BOX (J/B)  
 (M71), (E30) - ELECTRICAL UNITS

TKWT6853E

# COMBINATION METERS

< SERVICE INFORMATION >

DI-METER-02

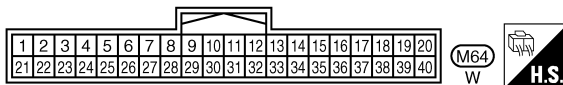
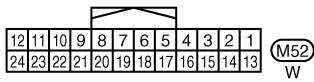
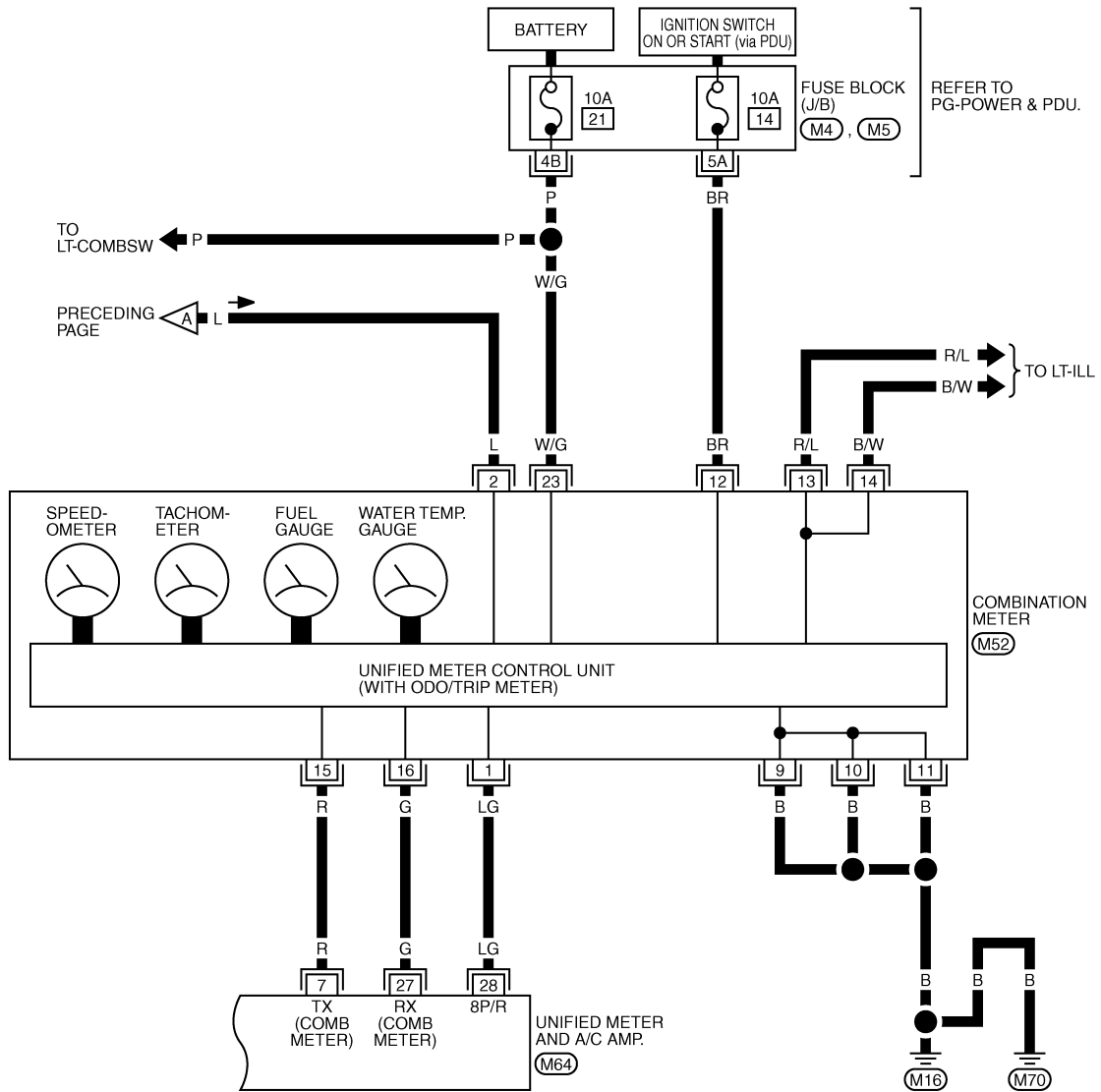

REFER TO THE FOLLOWING.  
**M4**, **M5** - FUSE BLOCK-JUNCTION BOX (J/B)

TKWT5082E

A  
B  
C  
D  
E  
F  
G  
H  
I  
J  
K  
L  
M  
N  
O  
P

DI

# COMBINATION METERS

< SERVICE INFORMATION >

## Terminal and Reference Value for Combination Meter

INFOID:00000002956880

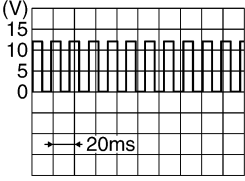
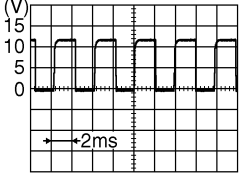
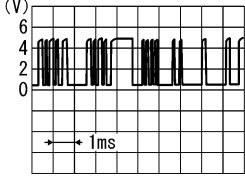
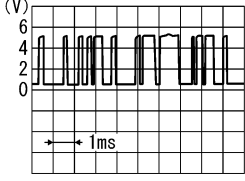
| Terminal No. | Wire color | Item  | Condition       |  | Reference value (Approx.)  |
|--------------|------------|---|-----------------|--|--|
|              |            |   | Ignition switch | Operation or condition   |  |
| 1            | LG         | Vehicle speed signal (8-pulse)                          | ON              | Speedometer operated [When vehicle speed is approx. 40 km/h (25 MPH)]      | <b>NOTE:</b><br>Maximum voltage may be 5 V due to specifications (connected units).<br> <p style="text-align: right; font-size: small;">PKIA1935E</p> |
| 2            | L          | ACC power supply  | ACC             | —  | Battery voltage  |
| 9            | B          | Ground  | ON              | —  | 0 V  |
| 10           |            |   |                 |  |  |
| 11           |            |   |                 |  |  |
| 12           | BR         | Ignition signal   | ON              | —  | Battery voltage  |
| 13           | R/L        | Illumination (+)  | ON              | Lighting switch is turned ON.  | 12 V   |
|              |            |   |                 | Lighting switch is turned OFF.   | 0 V  |
| 14           | B/W        | Illumination signal input                               | ON              | Lighting switch is turned ON, and illumination control switch is operated. | <e.g.> When brightness level is midway<br> <p style="text-align: right; font-size: small;">SKIB4733E</p>  |
|              |            |   |                 | Lighting switch is turned OFF.   | 0 V  |
| 15           | R          | RX communication line (From unified meter and A/C amp.) | ON              | —  |  <p style="text-align: right; font-size: small;">SKIA3362E</p>  |
| 16           | G          | TX communication line (To unified meter and A/C amp.)   | ON              | —  |  <p style="text-align: right; font-size: small;">SKIA3361E</p>  |
| 23           | W/G        | Battery power supply                                    | OFF             | —  | Battery voltage  |



# COMBINATION METERS

< SERVICE INFORMATION >

## Terminal and Reference Value for Unified Meter and A/C Amp

INFOID:00000002956881

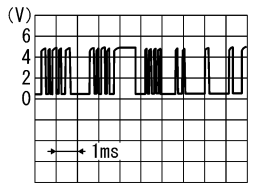
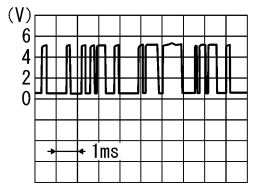
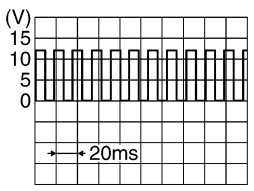
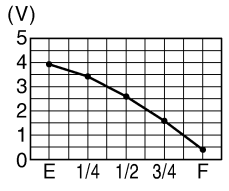
| Terminal No. | Wire color | Item  | Condition       |  | Reference value (Approx.)  |
|--------------|------------|---|-----------------|--|--|
|              |            |   | Ignition switch | Operation or condition   |  |
| 7            | R          | TX communication line<br>(To combination meter)   | ON              | —  |   |
| 27           | G          | RX communication line<br>(From combination meter) | ON              | —  |   |
| 28           | LG         | Vehicle speed signal output<br>(8-pulse)          | ON              | Speedometer operated<br>[When vehicle speed is approx. 40 km/h (25 MPH)] | <p><b>NOTE:</b><br/>Maximum voltage may be 5 V due to specifications (connected units).</p>  |
| 41           | V          | ACC power supply                                  | ACC             | —  | Battery voltage  |
| 42           | P/L        | Fuel level sensor signal                          | —               | —  |   |
| 53           | W/G        | Ignition signal                                   | ON              | —  | Battery voltage  |
| 54           | W/G        | Battery power supply                              | OFF             | —  | Battery voltage  |
| 55           | B          | Ground  | ON              | —  | 0 V  |
| 56           | L          | CAN-H   | —               | —  | —  |
| 58           | B          | Fuel level sensor ground                          | ON              | —  | 0 V  |
| 71           | B          | Ground (power)                                    | ON              | —  | 0 V  |
| 72           | P          | CAN-L   | —               | —  | —  |

### Self-Diagnosis Mode of Combination Meter

INFOID:00000002956882

#### SELF-DIAGNOSIS FUNCTION

- Odo/trip meter segment and dot matrix LCD segment operation can be checked in self-diagnosis mode.
- Meters/gauges can be checked in self-diagnosis mode.

#### OPERATION PROCEDURE

1. Turn ignition switch ON, and switch the odo/trip meter to “trip A” or “trip B”.

# COMBINATION METERS

## < SERVICE INFORMATION >

### NOTE:

If the diagnosis function is activated with "trip A" displayed, the mileage on "trip A" is reset to "0000.0". (The same way for "trip B".)

2. Turn ignition switch OFF.
3. While pressing the odometer/trip meter switch (1), turn ignition switch ON again.
4. Make sure that the trip meter displays "0000.0".
5. Press the odometer/trip meter switch (1) at least 3 times. (Within 7 seconds after the ignition switch is turned ON.)

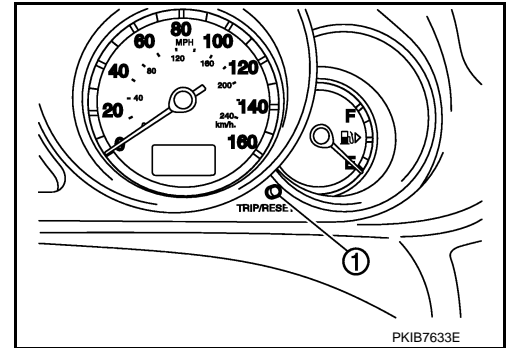

6. The unified meter control unit is turned to self-diagnosis mode.
  - Dot in all segments of dot matrix LCD (1) flashes alternately.
  - All the segments on the odometer/trip meter (2) illuminates.
  - Water temperature gauge and fuel gauge return to zero, and at the same time, low-fuel warning indicator turns ON.

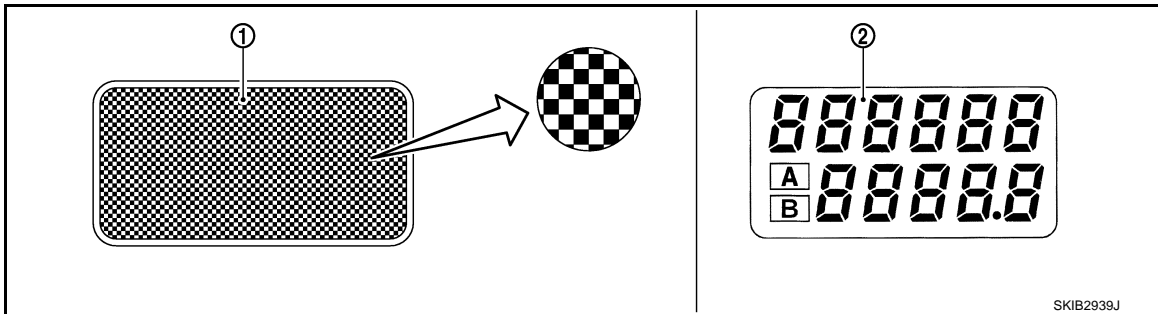

### NOTE:

- Check combination meter power supply and ground circuit when self-diagnosis mode of combination meter does not start. Replace combination meter if normal.
- If any of the segments is not displayed, replace combination meter.

7. Each meter activates during pressing odometer/trip meter switch. (Then low-fuel warning lamp turns OFF.)

### NOTE:

If any of the meter and gauges is not activated, replace combination meter.

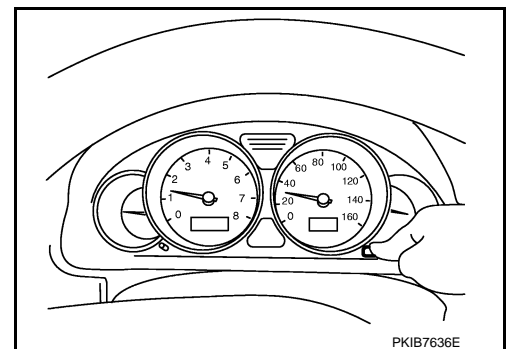

## CONSULT-III Function (METER/M&A)

INFOID:000000002956883

Refer to [DI-27. "CONSULT-III Function \(METER/M&A\)"](#) in "UNIFIED METER AND A/C AMP".

## Trouble Diagnosis

INFOID:000000002956884

### HOW TO PERFORM TROUBLE DIAGNOSIS

1. Confirm the symptom or customer complaint.
2. Perform preliminary check. Refer to "PRELIMINARY CHECK".
3. According to the symptom chart, make sure the cause of the symptom and repair or replace applicable parts. Refer to [DI-19. "Symptom Chart"](#).

# COMBINATION METERS

## < SERVICE INFORMATION >

4. Does the meter operate normally? If yes, GO TO 5. If no, GO TO 2.
5. INSPECTION END

### PRELIMINARY CHECK

#### 1.CHECK OPERATION SELF-DIAGNOSIS MODE OF COMBINATION METER

Perform self-diagnosis mode of combination meter. Refer to [DI-17, "Self-Diagnosis Mode of Combination Meter"](#).

Does self-diagnosis mode operate?

- YES >> GO TO 2.
- NO >> GO TO 3.

#### 2.CHECK UNIFIED METER AND A/C AMP. (CONSULT-III)

Perform self-diagnosis of unified meter and A/C amp. Refer to [DI-27, "CONSULT-III Function \(METER/M&A\)"](#).

Self-diagnostic results content

- No malfunction detected>>INSPECTION END
- Malfunction detected>>Check applicable parts, and repair or replace corresponding parts.

#### 3.CHECK POWER SUPPLY AND GROUND CIRCUIT OF COMBINATION METER

Check power supply and ground circuit of combination meter. Refer to [DI-19, "Power Supply and Ground Circuit Inspection"](#).

OK or NG

- OK >> Replace combination meter.
- NG >> Repair power supply and ground circuit of combination meter.

### Symptom Chart

INFOID:000000002956885

| Symptom  | Diagnosis/Service procedure  |
|--|--|
| Odo/trip meter indication is malfunction.          | Refer to <a href="#">DI-20, "Vehicle Speed Signal Inspection"</a> .              |
| Tachometer indication is malfunction.              | Refer to <a href="#">DI-21, "Engine Speed Signal Inspection"</a> .               |
| Water temperature gauge indication is malfunction. | Refer to <a href="#">DI-22, "Engine Coolant Temperature Signal Inspection"</a> . |
| Fuel gauge indication is malfunction.              | Refer to <a href="#">DI-22, "Fuel Level Sensor Signal Inspection"</a> .          |
| Low-fuel warning lamp indication is irregular.     |  |
| A/T position indicator is malfunction.             | Refer to <a href="#">DI-52, "A/T Indicator Is Malfunction"</a> .                 |

### Power Supply and Ground Circuit Inspection

INFOID:000000002956886

Symptom : When any power supply circuit is malfunction, the following function is not operative.

- BAT : Meter face illumination, Dot matrix LCD, Ring illumination, Turn signal/hazard indicator lights
- ACC : Meter face illumination, Dot matrix LCD, Pointer illumination, Speedometer, Tachometer
- IGN : Meter face illumination, Dot matrix LCD, Pointer illumination, Speedometer, Tachometer, Engine coolant temperature, Fuel gauge

#### 1.CHECK FUSE

Check for blown fuses.

| Power source                | Fuse No. |
|-----------------------------|----------|
| Battery                     | 21       |
| Ignition switch ACC or ON   | 6        |
| Ignition switch ON or START | 14       |

OK or NG

- OK >> GO TO 2.
- NG >> Be sure to eliminate cause of malfunction before installing new fuse. Refer to [PG-4](#).

#### 2.CHECK POWER SUPPLY CIRCUIT

# COMBINATION METERS

## < SERVICE INFORMATION >

Check voltage between combination meter harness connector and ground.

| Terminals                   |          | Ignition switch position |                 |                 |                 |
|-----------------------------|----------|--------------------------|-----------------|-----------------|-----------------|
| (+)                         |          | (-)                      | OFF             | ACC             | ON              |
| Combination meter connector | Terminal |                          |                 |                 |                 |
| M52                         | 23       | Ground                   | Battery voltage | Battery voltage | Battery voltage |
|                             | 2        |                          | 0 V             | Battery voltage | Battery voltage |
|                             | 12       |                          | 0 V             | 0 V             | Battery voltage |

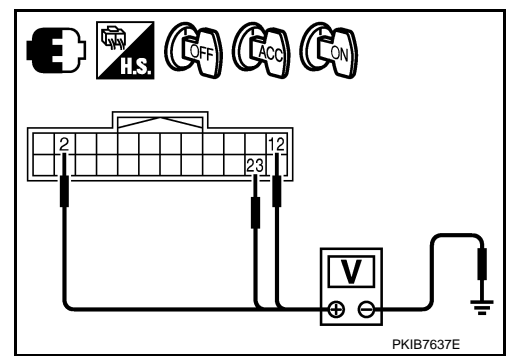

### OK or NG

- OK >> GO TO 3.
- NG >> Check harness between combination meter and fuse.

## 3. CHECK GROUND CIRCUIT

1. Turn ignition switch OFF.
2. Disconnect combination meter connector.
3. Check continuity between combination meter harness connector and ground.

| Combination meter connector | Terminal | Ground | Continuity |
|-----------------------------|----------|--------|------------|
| M52                         | 9        |        |            |
|                             | 10       |        |            |
|                             | 11       |        |            |

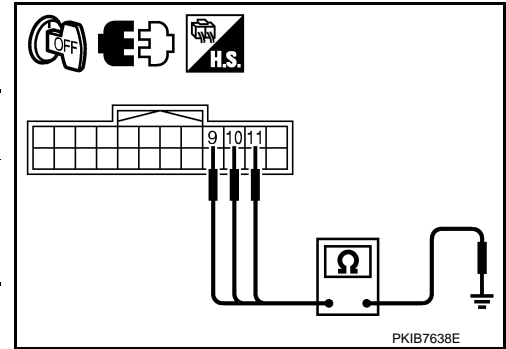

### OK or NG

- OK >> INSPECTION END
- NG >> Repair harness or connector.

## Vehicle Speed Signal Inspection

INFOID:000000002956887

Symptom: Odo/trip meter indication is malfunction.

### 1. CHECK UNIFIED METER AND A/C AMP. INPUT SIGNAL

1. Start the engine and select "METER/M&A" on CONSULT-III.
2. Compare the value in "SPEED METER" of "Data Monitor" in "METER/M&A" to that in speedometer in the combination meter during driving.

Is the value in speedometer almost same as that in the monitor?

YES >> Perform self-diagnosis of ABS actuator and electric unit (control unit). Refer to [BRC-30, "CONSULT-III Function \(ABS\)"](#).

NO >> GO TO 2.

### 2. CHECK UNIFIED METER AND A/C AMP. OUTPUT SIGNAL

1. Start engine and drive vehicle at approximately 40 km/h (25 MPH).

# COMBINATION METERS

## < SERVICE INFORMATION >

- Check voltage signal between unified meter and A/C amp. harness connector and ground.

| Terminals                           |          | Voltage (Approx.) |
|-------------------------------------|----------|-------------------|
| (+)                                 | (-)      |                   |
| Unified meter and A/C amp.connector | Terminal |                   |
| M64                                 | 28       | Ground            |

**NOTE:**

Maximum voltage may be 5 V due to specifications (connected units).

**OK or NG**

OK >> GO TO 3.

NG-1 >> If monitor indicates "0 V" constantly, perform the following.

- Check each unit inputting vehicle speed signal (8 pulse). Malfunction is caused by short circuit between each unit and unified meter and A/C amp.
- Repair or replace malfunctioning parts.

NG-2 >> If monitor indicates "5 V" or "12 V" constantly, replace unified meter and A/C amp.

### 3.CHECK CONTINUITY BETWEEN COMBINATION METER AND UNIFIED METER AND A/C AMP.

- Turn ignition switch OFF.
- Disconnect combination meter connector and unified meter and A/C amp. connector.
- Check continuity between combination meter harness connector (A) and unified meter and A/C amp. harness connector (B).

| A         |          | B         |          | Continuity |
|-----------|----------|-----------|----------|------------|
| Connector | Terminal | Connector | Terminal |            |
| M52       | 1        | M64       | 28       | Yes        |

**OK or NG**

OK >> Replace combination meter.

NG >> Repair harness or connector.

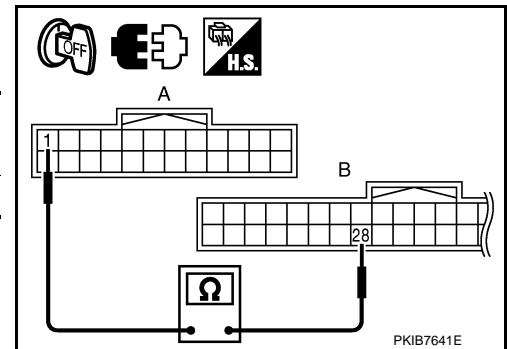
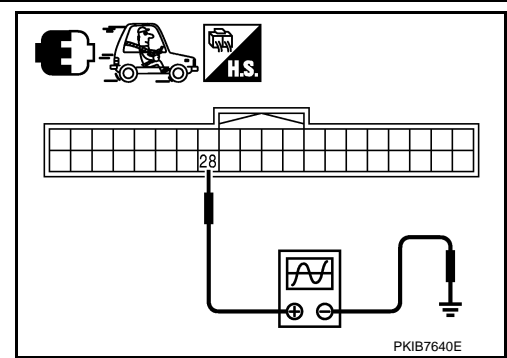

## Engine Speed Signal Inspection

Symptom: Tachometer indication is malfunction.

### 1.CHECK UNIFIED METER AND A/C AMP. INPUT SIGNAL

- Start the engine and select "METER/M&A" on CONSULT-III.
- Using "TACHO METER" on "Data Monitor", compare the value of "Data Monitor" to that of tachometer of combination meter.

Is the value in tachometer almost same as the value in the monitor?

OK >> GO TO 2.

NG >> Replace combination meter. (Perform self-diagnosis of ECM when the value in the monitor indicates 8191.875 rpm. Then repair or replace the malfunction part.)

### 2.CHECK ECM OUTPUT SIGNAL

- Select "ENGINE" on CONSULT-III.
- Using "ENG SPEED" on "Data Monitor", check the CONSULT-III screen when the engine is idling.
- Select "METER/M&A" on CONSULT-III.

INFOID:000000002956888

# COMBINATION METERS

## < SERVICE INFORMATION >

- Using "TACHO METER" on "Data Monitor", compare the value of "Data Monitor" of the idling speed with that of the "ENG SPEED".

### OK or NG

- OK >> Perform self-diagnosis of ECM. Refer to [EC-116, "CONSULT-III Function \(ENGINE\)"](#) (for VQ35DE) or [EC-741, "CONSULT-III Function"](#) (for VK45DE).
- NG >> Replace unified meter and A/C amp.

## Engine Coolant Temperature Signal Inspection

INFOID:000000002956889

Symptom: Water temperature gauge indication is malfunction.

### 1. CHECK UNIFIED METER AND A/C AMP. INPUT SIGNAL

- Start the engine and select "METER/M&A" on CONSULT-III.
- Using "W TEMP METER" on "Data Monitor", compare the value of "Data Monitor" to the indication of water temperature gauge of combination meter.

| Water temperature gauge pointer | Reference value of Data Monitor °C (°F) |
|---------------------------------|---|
| Hot                             | Approx. 130 (266)                       |
| Middle                          | Approx. 70 - 105 (158 - 221)            |
| Cold                            | Approx. 50 (122)                        |

Is the indication of water temperature gauge same as the value in the monitor?

- OK >> GO TO 2.
- NG >> Replace combination meter. [Perform self-diagnosis of ECM when the value in the monitor indicates 215°C (419°F). Then repair or replace the malfunction part.]

### 2. CHECK UNIFIED METER AND A/C AMP. INPUT SIGNAL

- Select "ENGINE" on CONSULT-III.
- Using "COOLAN TEMP/S" on "Data Monitor", check the CONSULT-III screen.
- Select "METER/M&A" on CONSULT-III.
- Using "W TEMP METER" on "Data Monitor", compare the value of "Data Monitor" to that of the "COOLAN TEMP/S".

### OK or NG

- OK >> Perform self-diagnosis of ECM. Refer to [EC-116, "CONSULT-III Function \(ENGINE\)"](#) (for VQ35DE) or [EC-741, "CONSULT-III Function"](#) (for VK45DE).
- NG >> Replace unified meter and A/C amp.

## Fuel Level Sensor Signal Inspection

INFOID:000000002956890

Symptom:

- Fuel gauge indication is malfunction.
- Low-fuel warning lamp indication is irregular.

### NOTE:

The following symptoms are not malfunction.

Fuel level sensor unit

- Depending on vehicle position or driving circumstance, the fuel level in the tank varies, and the pointer may fluctuate.

Low-fuel warning lamp

- Depending on vehicle position or driving circumstance, the fuel in the tank flows and the warning lamp ON timing may change.

### 1. CHECK UNIFIED METER AND A/C AMP. INPUT SIGNAL

- Select "METER/M&A" on CONSULT-III.
- Using "FUEL METER" on "Data Monitor", compare the value of "Data Monitor" to the indication of fuel gauge of combination meter.

# COMBINATION METERS

## < SERVICE INFORMATION >

| Fuel gauge pointer | Reference value of Data Monitor [lit.] |
|--------------------|--|
| Full               | Approx. 74                             |
| Three quarters     | Approx. 61                             |
| Half               | Approx. 42                             |
| A quarter          | Approx. 22                             |
| Empty              | Approx. 8                              |

### OK or NG

- OK >> GO TO 2.  
 NG >> Replace combination meter.

## 2. CHECK FUEL LEVEL SENSOR

- Turn ignition switch OFF.
- Check components. Refer to [DI-24. "Electrical Component Inspection"](#).

### OK or NG

- OK >> GO TO 3.  
 NG >> Replace fuel level sensor unit.

## 3. CHECK FUEL LEVEL SENSOR (SUB) CIRCUIT

- Disconnect unified meter and A/C amp. connector and fuel level sensor unit (sub) connector.
- Check continuity between unified meter and A/C amp. harness connector (A) and fuel level sensor unit (sub) harness connector (B).

| A         |          | B         |          | Continuity |
|-----------|----------|-----------|----------|------------|
| Connector | Terminal | Connector | Terminal |            |
| M65       | 42       | B52       | 1        | Yes        |

- Check continuity between unified meter and A/C amp. harness connector (A) and ground.

| A         |          | Ground | Continuity |
|-----------|----------|--------|------------|
| Connector | Terminal |        |            |
| M65       | 42       |        | No         |

### OK or NG

- OK >> GO TO 4.  
 NG >> Repair harness or connector.

## 4. CHECK FUEL LEVEL SENSOR (MAIN-SUB) CIRCUIT

- Disconnect fuel level sensor unit and fuel pump (main) connector.
- Check continuity between fuel level sensor unit (sub) harness connector (A) and fuel level sensor unit and fuel pump (main) harness connector (B).

| A         |          | B         |          | Continuity |
|-----------|----------|-----------|----------|------------|
| Connector | Terminal | Connector | Terminal |            |
| B52       | 2        | B433      | 2        | Yes        |

- Check continuity between fuel level sensor unit (sub) harness connector (A) and ground.

| A         |          | Ground | Continuity |
|-----------|----------|--------|------------|
| Connector | Terminal |        |            |
| B52       | 2        |        | No         |

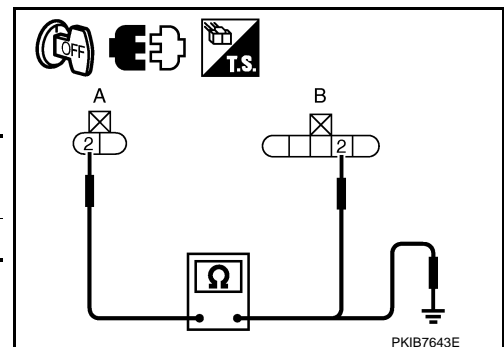
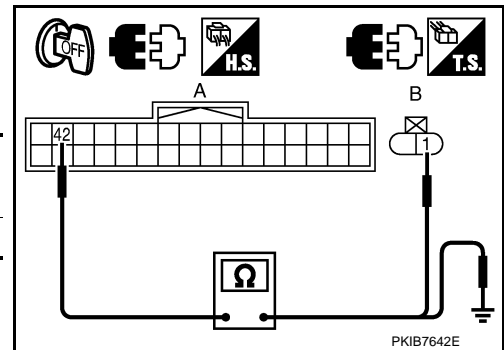

# COMBINATION METERS

## < SERVICE INFORMATION >

### OK or NG

- OK >> GO TO 5.
- NG >> Repair harness or connector.

## 5. CHECK FUEL LEVEL SENSOR (MAIN) CIRCUIT

Check continuity between fuel level sensor unit and fuel pump (main) harness connector (A) and unified meter and A/C amp. harness connector (B).

| A         |          | B         |          | Continuity |
|-----------|----------|-----------|----------|------------|
| Connector | Terminal | Connector | Terminal |            |
| B433      | 5        | M65       | 58       | Yes        |

### OK or NG

- OK >> GO TO 6.
- NG >> Repair harness or connector.

## 6. CHECK INSTALLATION CONDITION

Check fuel level sensor unit installation, and check whether the float arm interferes or binds with any of the internal components in the fuel tank.

### OK or NG

- OK >> Replace unified meter and A/C amp.
- NG >> Install the fuel level sensor unit properly.

## Electrical Component Inspection

INFOID:000000002956893

### CHECK FUEL LEVEL SENSOR UNIT

For removal, refer to [FL-4, "Component"](#).

Check Fuel Level Sensor Unit and Fuel Pump (Main)  
Check resistance between terminals 2 and 5.

| Terminal |   | Float position [mm (in)] |       | Resistance value [ $\Omega$ ] |
|----------|---|--------------------------|-------|-------------------------------|
| 2        | 5 | *1                       | Full  | 211 (8.31)                    |
|          |   | *2                       | Empty | 31 (1.22)                     |

\*1 and \*2: When float rod is in contact with stopper.

- If the results of check are NG, check the fuel level sensor unit and fuel pump (main) harness. Refer to "Check Fuel Level Sensor Unit and Pump (Main) Harness".

Check Fuel Level Sensor Unit and Pump (Main) Harness  
Check continuity at following terminals.

| Terminal                | Continuity |
|-------------------------|------------|
| 2 - Signal terminal (A) | Yes        |
| 5 - Ground terminal (B) |            |

- If the results of check are NG, replace fuel pump assembly. If the results of check are OK, replace fuel level sensor unit.

Check Fuel Level Sensor Unit (Sub)

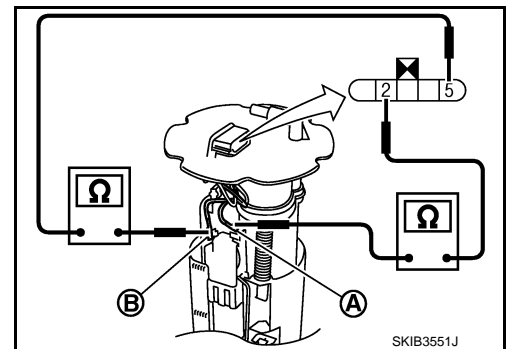
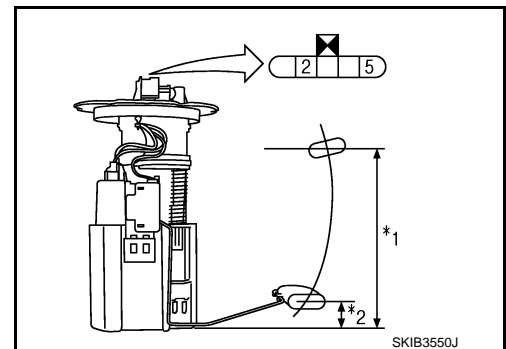
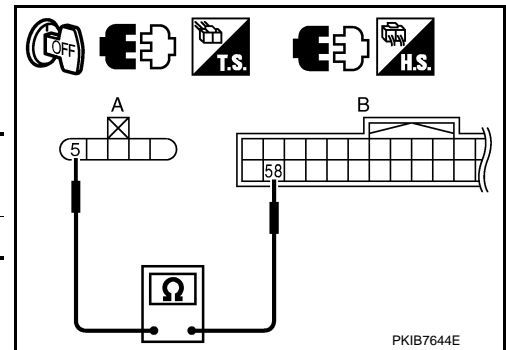



# COMBINATION METERS

## < SERVICE INFORMATION >

Check resistance between terminals 1 and 2.

| Terminal |   | Float position [mm (in)] |       | Resistance value [ $\Omega$ ] |            |
|----------|---|--------------------------|-------|-------------------------------|------------|
| 1        | 2 | *1                       | Full  | 9 (0.35)                      | Approx. 3  |
|          |   | *2                       | Empty | 179 (7.05)                    | Approx. 43 |

\*1 and \*2: When float rod is in contact with stopper.

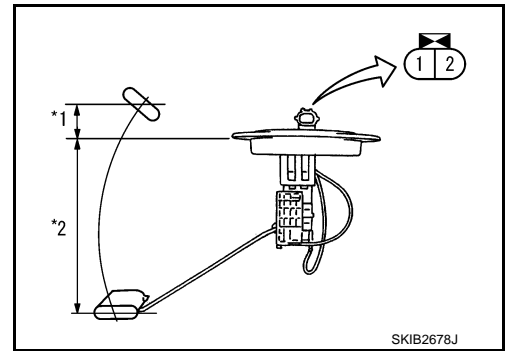

INFOID:000000002956894

## Removal and Installation of Combination Meter

### REMOVAL

1. Remove cluster lid A. Refer to [IP-11, "INSTRUMENT PANEL : Component Parts Location"](#).
2. Remove the screws (A) using power tools, and pull out combination meter (1).
3. Disconnect connector, and remove combination meter (1).

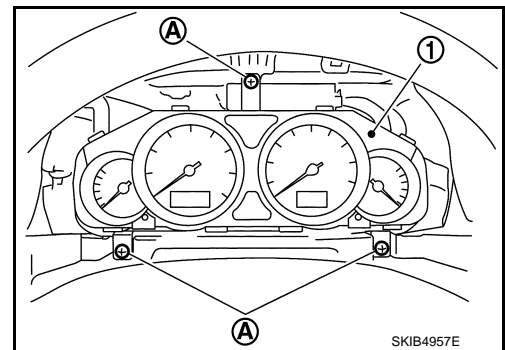

### INSTALLATION

Installation is the reverse order of removal.

## Disassembly and Assembly of Combination Meter

INFOID:000000002956895

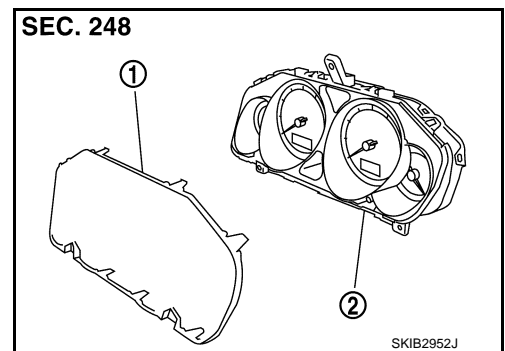

1. Front cover
2. Unified meter control unit

### DISASSEMBLY

Disengage tabs to separate front cover.

### ASSEMBLY

Assembly is the reverse order of disassembly.

# UNIFIED METER AND A/C AMP

< SERVICE INFORMATION >

## UNIFIED METER AND A/C AMP

### System Description

INFOID:000000002956896

For the unified meter and A/C amp., the signal required for controlling the combination meter are integrated in the A/C auto amp.

### COMBINATION METER CONTROL FUNCTION

- Unified meter and A/C amp. inputs necessary information for combination meter from each unit with CAN communication and so on.
- Unified meter and A/C amp. outputs signals with communication line (TX, RX) between unified meter and A/C amp. and combination meter.
- Unified meter and A/C amp. corresponds a CONSULT-III function (Self Diagnostic Result, CAN Diagnostic Support Monitor and Data Monitor).

### Input/output Signals

Between unified meter and A/C amp. and combination meter.

| Unit                       | Input from combination meter   | Output to combination meter  |
|----------------------------|--|--|
| Unified meter and A/C amp. | <ul style="list-style-type: none"> <li>• Refuel status signal</li> <li>• Low-fuel warning lamp condition signal</li> <li>• Delivery destination data signal</li> <li>• Combination meter receive error signal</li> <li>• Combination meter specifications signal</li> <li>• Odo date signal</li> </ul> | <ul style="list-style-type: none"> <li>• Vehicle speed signal</li> <li>• Turn indicator signal</li> <li>• High beam request signal</li> <li>• Ring illumination request signal</li> <li>• Position light request signal</li> <li>• Front fog lamp request signal</li> <li>• SET indicator lamp signal</li> <li>• CRUISE indicator lamp signal</li> <li>• Engine speed signal</li> <li>• Fuel level sensor signal (resistance value)</li> <li>• Engine coolant temperature signal</li> <li>• CAN communication condition signal of A/T</li> <li>• A/T position indicator signal</li> <li>• Manual mode indicator signal</li> <li>• A/T CHECK warning lamp signal</li> <li>• AWD warning lamp signal</li> <li>• Low tire pressure warning lamp signal</li> <li>• VDC OFF indicator lamp signal</li> <li>• SLIP indicator lamp signal</li> <li>• ABS warning lamp signal</li> <li>• Brake warning lamp signal</li> <li>• Malfunction indicator lamp signal</li> <li>• Oil pressure switch signal</li> <li>• Door switch signal</li> <li>• Buzzer request signal</li> <li>• ICC warning lamp signal</li> <li>• Meter display signal</li> <li>• AFS OFF indicator signal</li> </ul> |

### A/C AUTO AMP. FUNCTION

Unified meter and A/C amp. controls each operation for A/C auto amp. Regarding A/C control, refer to [ATC-26. "Description of Air Conditioner LAN Control System"](#).

### OTHER FUNCTIONS

#### Drive Computer Function

The signals required for the distance to empty (DTE) display are centralized in the unified meter and A/C amp., converted into data, and transmit to the AV control unit with CAN communication.

#### Signal Buffer Function

Unified meter and A/C amp. transmits each signal to other units with CAN communication.

# UNIFIED METER AND A/C AMP

< SERVICE INFORMATION >

## Schematic

INFOID:000000002956897

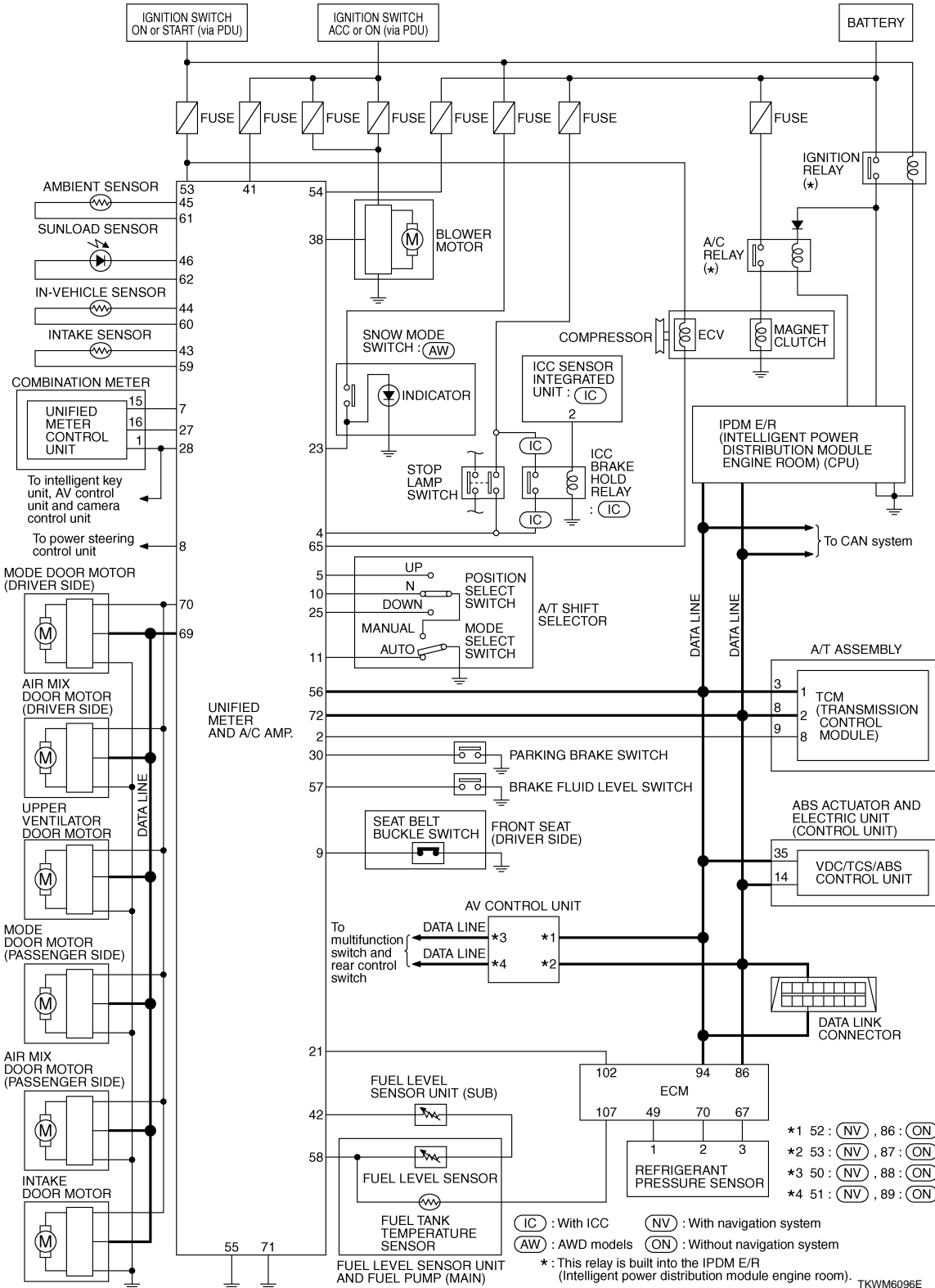

A  
B  
C  
D  
E  
F  
G  
H  
I  
J  
DI  
L  
M  
N  
O  
P

# UNIFIED METER AND A/C AMP

## < SERVICE INFORMATION >

| System        | Diagnosis mode         | Description  |
|---------------|------------------------|--|
| METER/<br>M&A | Self Diagnostic Result | Unified meter and A/C amp. checks the conditions and displays memorized error. |
|               | CAN DIAG SUPPORT MNTR  | The results of transmit/receive diagnosis of CAN communication can be read.    |
|               | Data Monitor           | Displays unified meter and A/C amp. input data in real time.                   |

## SELF-DIAG RESULTS

### Display Item List

| Display item [Code]              | Malfunction is detected when...   | Reference page        |
|----------------------------------|---|-----------------------|
| CAN COMM CIRC<br>[U1000]         | When combination meter is not transmitting or receiving CAN communication signal for 2 seconds or more.<br><b>NOTE:</b><br>Even when there is no malfunction on CAN communication system, malfunction may be misinterpreted when battery has low voltage (when maintaining 7 - 8 V for about 2 seconds) or 10A fuse [NO.19, located in the fuse block (J/B)] is disconnected. | <a href="#">DI-30</a> |
| METER COMM CIRC<br>[B2202]       | Malfunction is detected in communication between combination meter and unified meter and A/C amp.   | <a href="#">DI-30</a> |
| VEHICLE SPEED<br>CIRC<br>[B2205] | If the abnormal vehicle speed signal is input from ABS actuator and electric unit (control unit) for 2 seconds or more.<br><b>NOTE:</b><br>Even when there is no malfunction on CAN communication system, malfunction may be misinterpreted when battery has low voltage (when maintaining 7 - 8 V for about 2 seconds).  | <a href="#">DI-30</a> |

### NOTE:

“TIME” means the following.

- 0: Means detected malfunction at present. (From malfunction detection to turning ignition switch OFF)
- 1-63: Means detected malfunction in past. (Displays number of ignition switch OFF → ON after detecting malfunction. “Self-diagnosis result” is erased when exceeding “63”.)

## Data Monitor

### Display Item List

X: Applicable

| Display item [Unit]    | MAIN SIGNALS | SELECTION FROM MENU | Description   |
|------------------------|--------------|---------------------|---|
| SPEED METER [km/h]     | X            | X                   | Displays the value of vehicle speed signal, which is input from ABS actuator and electric unit (control unit).  |
| SPEED OUTPUT [km/h]    | X            | X                   | Displays the value of vehicle speed signal, which is transmitted to each unit with CAN communication.   |
| TACHO METER [rpm]      | X            | X                   | Displays the value of engine speed signal, which is input from ECM.   |
| W TEMP METER [°C]      | X            | X                   | Displays the value of engine coolant temperature signal, which is input from ECM.   |
| FUEL METER [lit.]      | X            | X                   | Displays the value, which processes a resistance signal from fuel gauge.  |
| DISTANCE [km]          | X            | X                   | Displays the value, which is calculated by vehicle speed signal from ABS actuator and electric unit (control unit), fuel gauge and fuel consumption from ECM. |
| FUEL W/L [On/Off]      | X            | X                   | Displays [On/Off] condition of low-fuel warning lamp.   |
| MIL [On/Off]           |              | X                   | Displays [On/Off] condition of malfunction indicator lamp.  |
| AIR PRES W/L [On/Off]  |              | X                   | Displays [On/Off] condition of low tire pressure warning lamp.  |
| SEAT BELT W/L [On/Off] |              | X                   | Displays [On/Off] condition of seat belt warning lamp.  |
| BUZZER [On/Off]        | X            | X                   | Displays [On/Off] condition of buzzer.  |
| DOOR W/L [On/Off]      |              | X                   | Displays [On/Off] condition of door warning lamp.   |
| HI-BEAM IND [On/Off]   |              | X                   | Displays [On/Off] condition of high beam indicator lamp.  |

# UNIFIED METER AND A/C AMP

## < SERVICE INFORMATION >

| Display item [Unit]    | MAIN SIGNALS | SELECTION FROM MENU | Description   |
|------------------------|--------------|---------------------|---|
| TURN IND [On/Off]      |              | X                   | Displays [On/Off] condition of turn indicator lamp.                 |
| FR FOG IND [On/Off]    |              | X                   | Displays [On/Off] condition of front fog lamp indicator lamp.       |
| OIL W/L [On/Off]       |              | X                   | Displays [On/Off] condition of oil pressure warning lamp.           |
| LIGHT IND [On/Off]     |              | X                   | Displays [On/Off] condition of light indicator lamp.                |
| VDC/TCS IND [On/Off]   |              | X                   | Displays [On/Off] condition of VDC/TCS OFF indicator lamp.          |
| ABS W/L [On/Off]       |              | X                   | Displays [On/Off] condition of ABS warning lamp.                    |
| SLIP IND [On/Off]      |              | X                   | Displays [On/Off] condition of SLIP indicator lamp.                 |
| BRAKE W/L [On/Off]     |              | X                   | Displays [On/Off] condition of brake warning lamp. *                |
| KEY G/Y W/L [On/Off]   |              | X                   | Displays [On/Off] condition of key warning lamp.                    |
| PNP P SW [On/Off]      | X            | X                   | Displays [On/Off] condition of inhibitor switch P range.            |
| M RANGE SW [On/Off]    | X            | X                   | Displays [On/Off] condition of manual mode range switch.            |
| NM RANGE SW [On/Off]   | X            | X                   | Displays [On/Off] condition of except for manual mode range switch. |
| AT SFT UP SW [On/Off]  | X            | X                   | Displays [On/Off] condition of A/T shift-up switch.                 |
| AT SFT DWN SW [On/Off] | X            | X                   | Displays [On/Off] condition of A/T shift-down switch.               |
| AT P MODE SW           |              | X                   | This item is displayed, but not is monitored.                       |
| AT S MODE SW           |              | X                   | Displays [On/Off] condition of A/T SNOW mode switch.                |
| BRAKE SW [On/Off]      |              | X                   | Displays [On/Off] condition of brake switch (stop lamp switch).     |
| AT-M IND [On/Off]      | X            | X                   | Displays [On/Off] condition of A/T manual mode indicator.           |
| AT-M GEAR [5-1]        | X            | X                   | Displays [5-1] condition of A/T manual mode gear position.          |
| P RANGE IND [On/Off]   | X            | X                   | Displays [On/Off] condition of A/T shift P range indicator.         |
| R RANGE IND [On/Off]   | X            | X                   | Displays [On/Off] condition of A/T shift R range indicator.         |
| N RANGE IND [On/Off]   | X            | X                   | Displays [On/Off] condition of A/T shift N range indicator.         |
| D RANGE IND [On/Off]   | X            | X                   | Displays [On/Off] condition of A/T shift D range indicator.         |
| AT CHECK W/L [On/Off]  |              | X                   | Displays [On/Off] condition of A/T check warning lamp.              |
| CRUISE IND [On/Off]    |              | X                   | Displays [On/Off] condition of CRUISE indicator lamp.               |
| SET IND [On/Off]       |              | X                   | Displays [On/Off] condition of SET indicator lamp.                  |
| CRUISE W/L [On/Off]    |              | X                   | Displays [On/Off] condition of CRUISE warning lamp.                 |
| 4WD W/L [On/Off]       |              | X                   | Displays [On/Off] condition of AWD warning lamp.                    |
| BRAKE AST              |              | X                   | This item is displayed, but not is monitored.                       |
| AFS OFF IND [On/Off]   |              | X                   | Displays [On/Off] condition of AFS OFF indicator lamp.              |

**NOTE:**

Monitored item that does not match the vehicle is deleted from the display automatically.

\*: Monitor keeps indicating "Off" when brake warning lamp is on by the parking brake operation or low brake fluid level.

## Power Supply and Ground Circuit Inspection

INFOID:000000002956899

### 1. CHECK FUSE

Check for blown fuses.

| Power source                | Fuse No. |
|-----------------------------|----------|
| Battery                     | 19       |
| Ignition switch ACC or ON   | 6        |
| Ignition switch ON or START | 12       |

**OK or NG**

OK >> GO TO 2.

NG >> Be sure to eliminate cause of malfunction before installing new fuse. Refer to [PG-4, "Schematic"](#).

# UNIFIED METER AND A/C AMP

< SERVICE INFORMATION >

## 2. CHECK POWER SUPPLY CIRCUIT

Check voltage between unified meter and A/C amp. harness connector terminals and ground.

| Terminals                            |          | Ignition switch position |                 |                 |                 |
|--------------------------------------|----------|--------------------------|-----------------|-----------------|-----------------|
| (+)                                  |          | (-)                      | OFF             | ACC             | ON              |
| Unified meter and A/C amp. connector | Terminal |                          |                 |                 |                 |
| M65                                  | 54       | Ground                   | Battery voltage | Battery voltage | Battery voltage |
|                                      | 41       |                          | 0 V             | Battery voltage | Battery voltage |
|                                      | 53       |                          | 0 V             | 0 V             | Battery voltage |

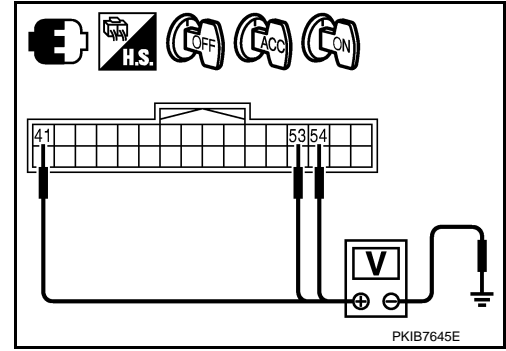

**OK or NG**

OK >> GO TO 3.

NG >> Check harness between unified meter and A/C amp. and fuse.

## 3. CHECK GROUND CIRCUIT

1. Turn ignition switch OFF.
2. Disconnect unified meter and A/C amp. connector.
3. Check continuity between unified meter and A/C amp. harness connector and ground.

| Unified meter and A/C amp. connector | Terminal | Ground | Continuity |
|--------------------------------------|----------|--------|------------|
| M65                                  | 55       | Ground | Yes        |
|                                      | 71       |        |            |

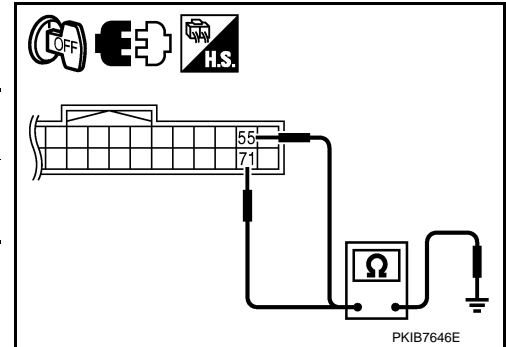

**OK or NG**

OK >> INSPECTION END

NG >> Repair harness or connector.

## DTC [U1000] CAN Communication Circuit

INFOID:000000003301994

Symptom: Display "CAN COMM CIRC [U1000]" at the result of self-diagnosis for unified meter and A/C amp.

### 1. CHECK CAN COMMUNICATION

1. Turn ignition switch ON and wait for 2 seconds or more.
2. Check "Self Diagnostic Result" of "METER/M&A"

YES >> Refer to [LAN-20. "Trouble Diagnosis Flow Chart"](#).

NO >> Refer to [GI-36. "CONSULT-III/GST Data Link Connector \(DLC\) Circuit"](#).

## DTC [B2202] Meter Communication Circuit

INFOID:000000002956901

Symptom: Displays "METER COMM CIRC [B2202]" as a self-diagnosis results of unified meter and A/C amp.

### 1. CHECK CONNECTOR

Check combination meter, unified meter and A/C amp. and terminals (combination meter side, unified meter and A/C amp. side, and harness side) for looseness or bent.

**OK or NG**

OK >> GO TO 2.

NG >> Repair terminal or connector.

### 2. CHECK CONTINUITY COMMUNICATION CIRCUIT (TX: UNIFIED METER AND A/C AMP.)

# UNIFIED METER AND A/C AMP

## < SERVICE INFORMATION >

1. Turn ignition switch OFF.
2. Disconnect combination meter connector and unified meter and A/C amp. connector.
3. Check continuity between combination meter harness connector (A) and unified meter and A/C amp. harness connector (B).

| A         |          | B         |          | Continuity |
|-----------|----------|-----------|----------|------------|
| Connector | Terminal | Connector | Terminal |            |
| M52       | 15       | M64       | 7        | Yes        |

4. Check continuity between combination meter harness connector (A) and ground.

| A         |          | Ground | Continuity |
|-----------|----------|--------|------------|
| Connector | Terminal |        |            |
| M52       | 15       |        | No         |

### OK or NG

- OK >> GO TO 3.  
 NG >> Repair harness or connector.

## 3. CHECK CONTINUITY COMMUNICATION CIRCUIT (RX: UNIFIED METER AND A/C AMP.)

1. Check continuity between combination meter harness connector (A) and unified meter and A/C amp. harness connector (B).

| A         |          | B         |          | Continuity |
|-----------|----------|-----------|----------|------------|
| Connector | Terminal | Connector | Terminal |            |
| M52       | 16       | M64       | 27       | Yes        |

2. Check continuity between combination meter harness connector (A) and ground.

| A         |          | Ground | Continuity |
|-----------|----------|--------|------------|
| Connector | Terminal |        |            |
| M52       | 16       |        | No         |

### OK or NG

- OK >> GO TO 4.  
 NG >> Repair harness or connector.

## 4. CHECK COMBINATION METER OUTPUT VOLTAGE (TX: UNIFIED METER AND A/C AMP.)

1. Connect combination meter connector.
2. Turn ignition switch ON.
3. Check voltage between combination meter harness connector and ground.

| Terminals                   |          |        | Voltage (Approx.) |
|-----------------------------|----------|--------|-------------------|
| (+)                         |          | (-)    |                   |
| Combination meter connector | Terminal |        |                   |
| M52                         | 15       | Ground | 5 V               |

### OK or NG

- OK >> GO TO 5.  
 NG >> Replace combination meter.

## 5. CHECK COMMUNICATION SIGNAL (TX: UNIFIED METER AND A/C AMP.)

1. Turn ignition switch OFF.
2. Connect unified meter and A/C amp. connector.

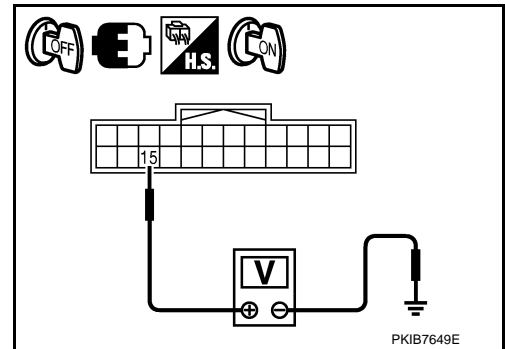
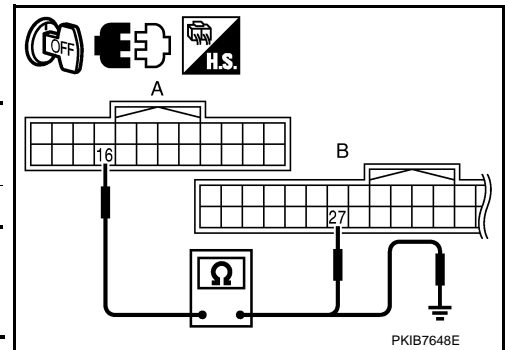
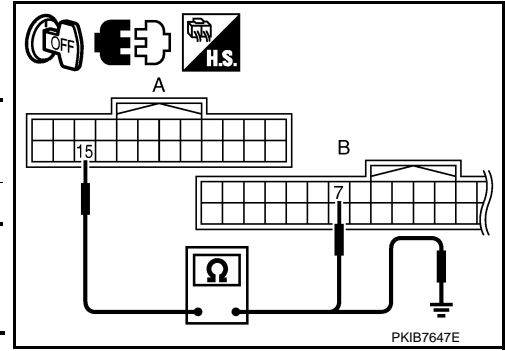

A  
B  
C  
D  
E  
F  
G  
H  
I  
J  
L  
M  
N  
O  
P

DI

# UNIFIED METER AND A/C AMP

## < SERVICE INFORMATION >

- Turn ignition switch ON.
- Check voltage signal between combination meter harness connector and ground.

| Terminals                   |          | (-)    | Voltage (Approx.)            |
|-----------------------------|----------|--------|------------------------------|
| (+)                         |          |        |                              |
| Combination meter connector | Terminal |        |                              |
| M52                         | 15       | Ground | <br><small>SKIA3362E</small> |

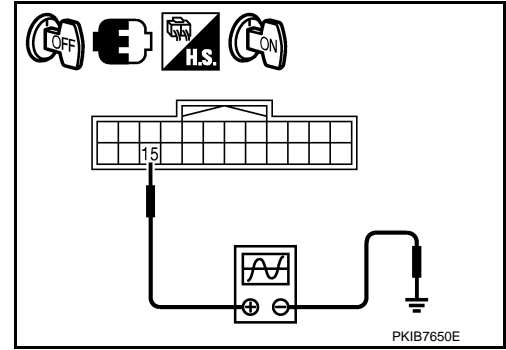

### OK or NG

- OK >> GO TO 6.  
 NG >> Replace unified meter and A/C amp.

## 6. CHECK UNIFIED METER AND A/C AMP OUTPUT VOLTAGE (RX: UNIFIED METER AND A/C AMP.)

- Turn ignition switch OFF.
- Disconnect combination meter connector.
- Turn ignition switch ON.
- Check voltage between unified meter and A/C amp. harness connector and ground.

| Terminals                            |          | (-)    | Voltage (Approx.) |
|--------------------------------------|----------|--------|-------------------|
| (+)                                  |          |        |                   |
| Unified meter and A/C amp. connector | Terminal |        |                   |
| M64                                  | 27       | Ground | 5 V               |

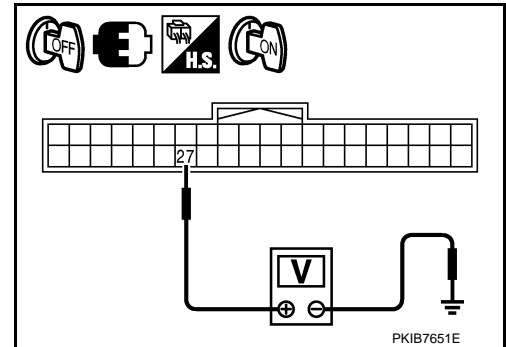

### OK or NG

- OK >> GO TO 7.  
 NG >> Replace unified meter and A/C amp.

## 7. CHECK COMMUNICATION SIGNAL (RX: UNIFIED METER AND A/C AMP.)

- Turn ignition switch OFF.
- Connect combination meter connector.
- Turn ignition switch ON.
- Check voltage signal between unified meter and A/C amp. harness connector and ground.

| Terminals                            |          | (-)    | Voltage (Approx.)            |
|--------------------------------------|----------|--------|------------------------------|
| (+)                                  |          |        |                              |
| Unified meter and A/C amp. connector | Terminal |        |                              |
| M64                                  | 27       | Ground | <br><small>SKIA3361E</small> |

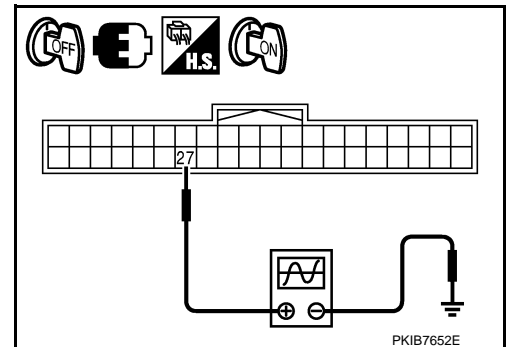



# UNIFIED METER AND A/C AMP

## < SERVICE INFORMATION >

### OK or NG

- OK >> Replace unified meter and A/C amp.
- NG >> Replace combination meter.

## DTC [B2205] Vehicle Speed Circuit

INFOID:000000002956902

Symptom: Displays "VEHICLE SPEED CIRC [B2205]" as a self-diagnosis results of unified meter and A/C amp.

Perform self-diagnosis of ABS actuator and electric unit (control unit), and repair or replace malfunctioning parts. Refer to [BRC-30, "CONSULT-III Function \(ABS\)"](#).

## Removal and Installation of Unified Meter and A/C Amp

INFOID:000000003468527

### REMOVAL

1. Remove the AV control unit. Refer to the following.
  - [AV-482, "Removal and Installation"](#) (Without mobile entertainment system)
  - [AV-1064, "Removal and Installation"](#) (With mobile entertainment system)
2. Remove the screws (A) 2.
3. Remove the screws (B) 8 and remove the bracket (1).
4. Remove unified meter and A/C amp. (2).

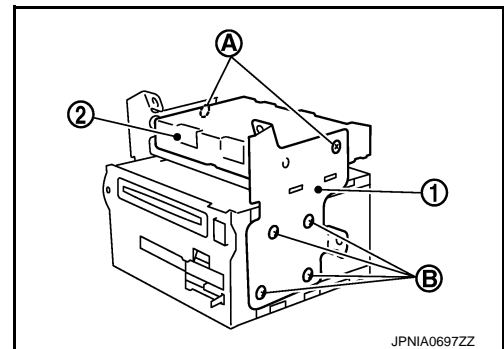

### INSTALLATION

Installation is the reverse order of removal.

#### **CAUTION:**

**Unified meter and A/C amp. screws are different from other screws. Never confuse them when installing.**

# WARNING LAMPS

< SERVICE INFORMATION >

## WARNING LAMPS

### System Description

INFOID:000000002956904

#### OIL PRESSURE WARNING LAMP

Oil pressure warning lamp turns ON when reducing engine oil pressure abnormally.

- IPDM E/R inputs oil pressure switch signal from oil pressure switch, and transmits the signal to unified meter and A/C amp. through BCM with CAN communication.
- Unified meter and A/C amp. transmits oil pressure switch signal to combination meter with communication line.
- Let the combination meter turn oil pressure warning lamp ON with received oil pressure switch signal.

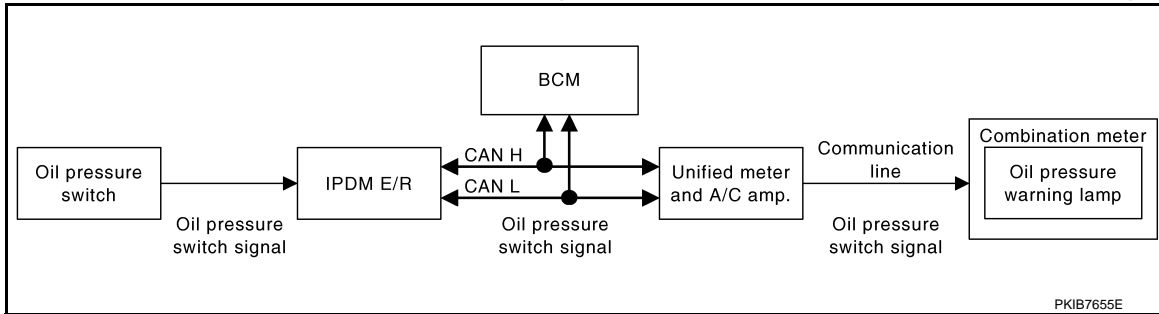

# WARNING LAMPS

< SERVICE INFORMATION >

## Component Parts and Harness Connector Location

INFOID:000000002956905

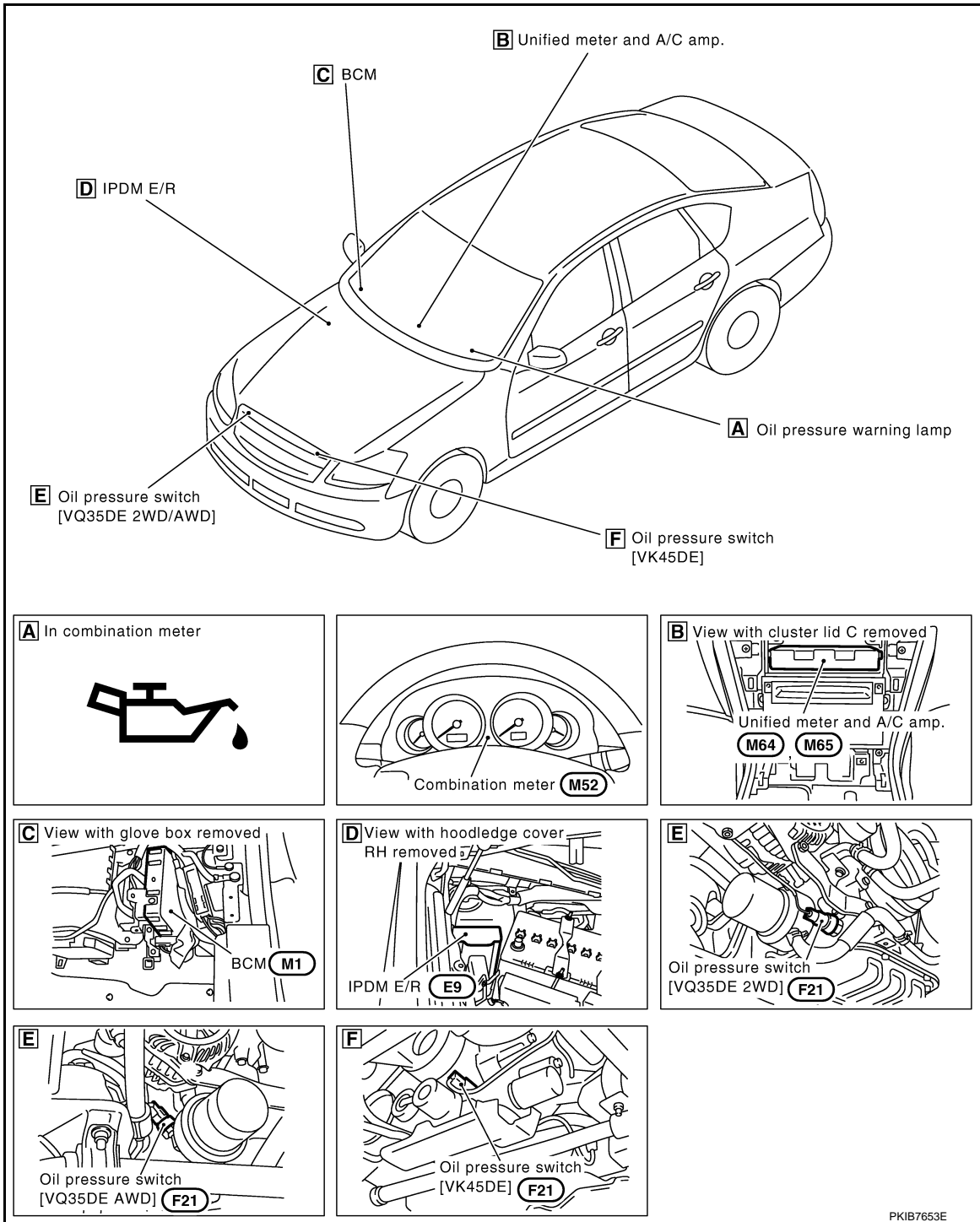

A  
B  
C  
D  
E  
F  
G  
H  
I  
J  
K  
L  
M  
N  
O  
P

DI

# WARNING LAMPS

< SERVICE INFORMATION >

## Schematic

INFOID:00000002956906

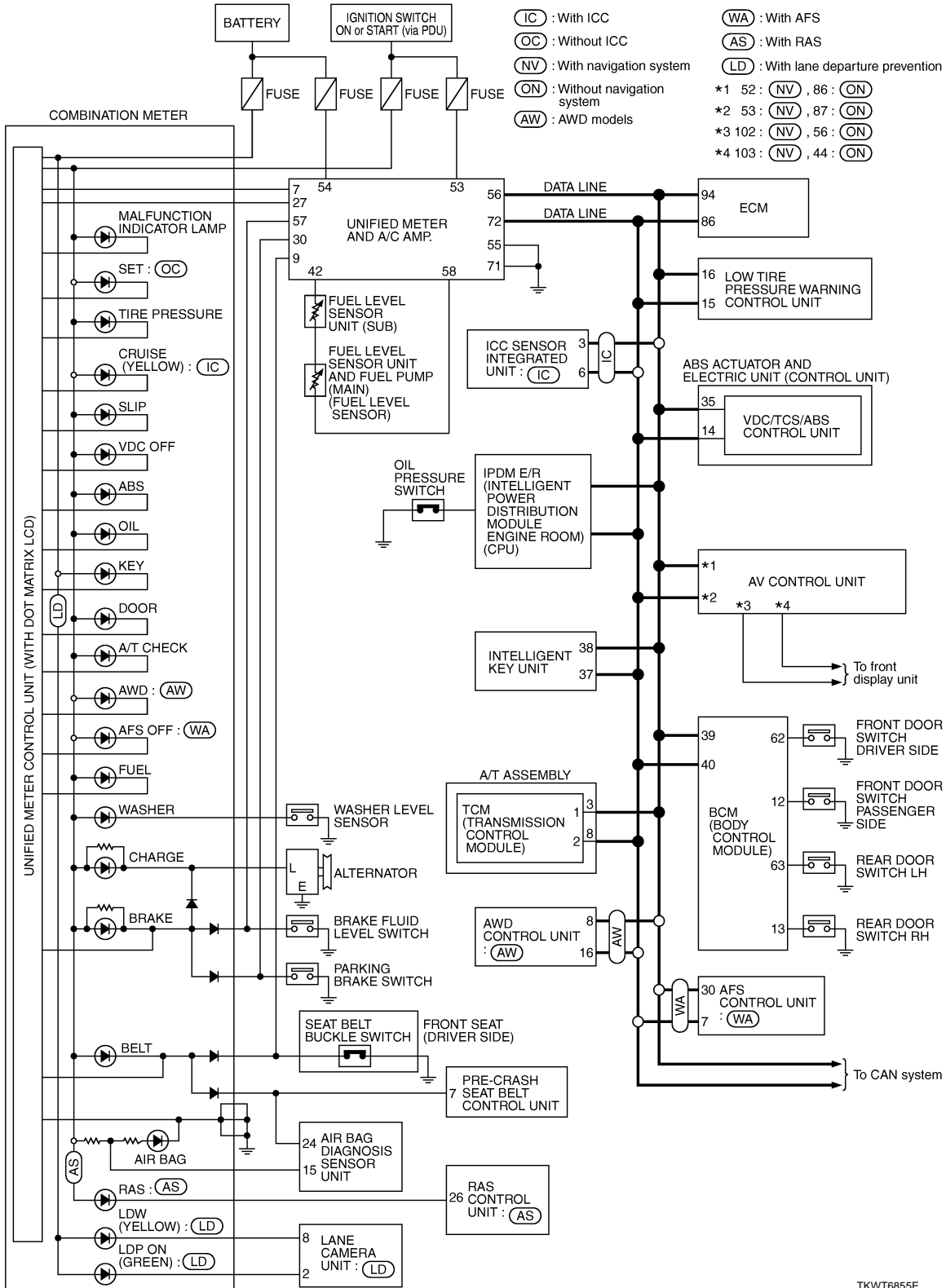

**NOTE:**  
For the further details, refer to descriptions on each system.

TKWT6855E

# WARNING LAMPS

< SERVICE INFORMATION >

## Wiring Diagram - WARN -

INFOID:00000002956907

### DI-WARN-01

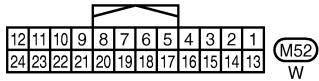
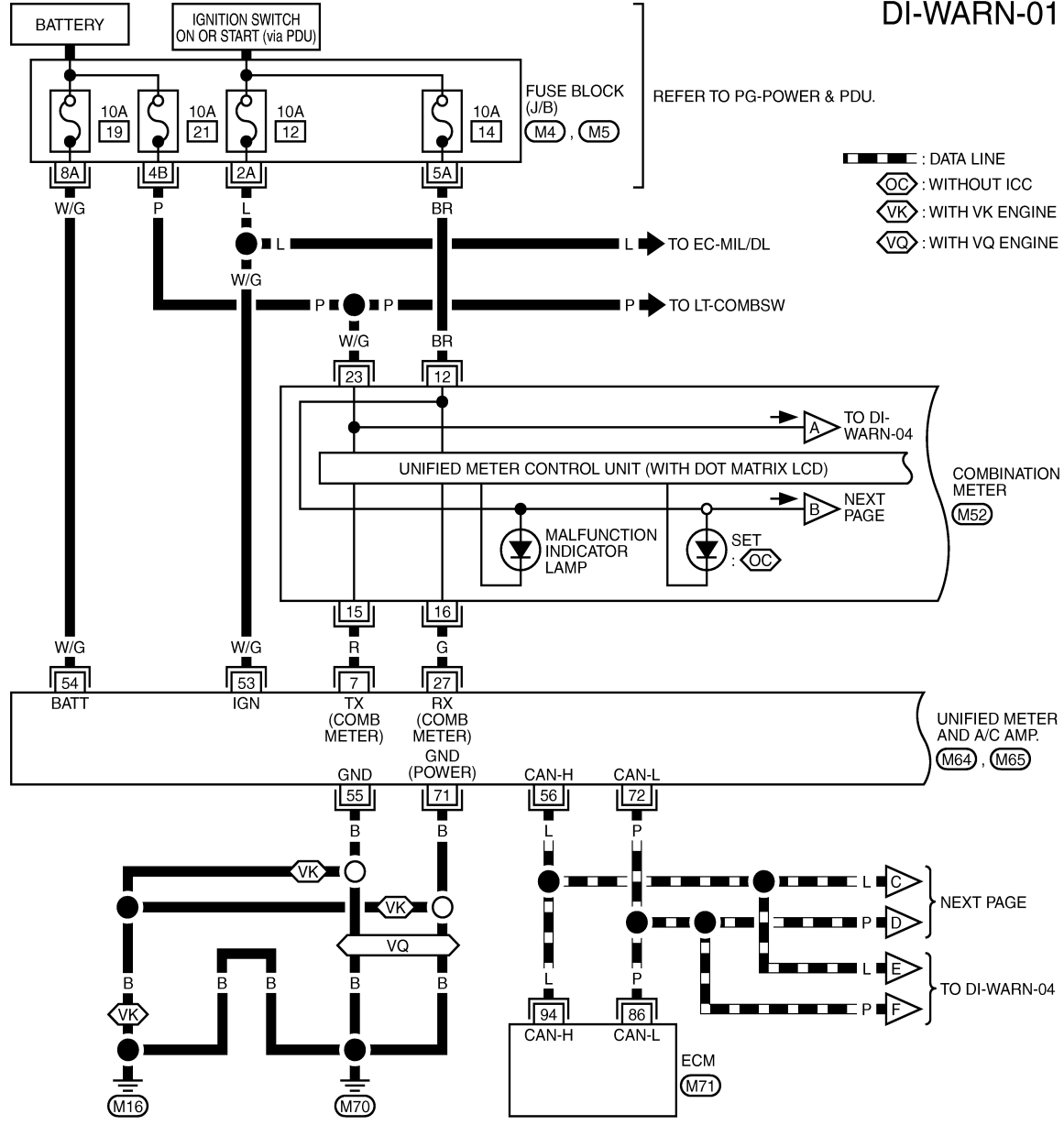

REFER TO THE FOLLOWING.  
 (M4), (M5) - FUSE BLOCK - JUNCTION BOX (J/B)  
 (M71) - ELECTRICAL UNITS

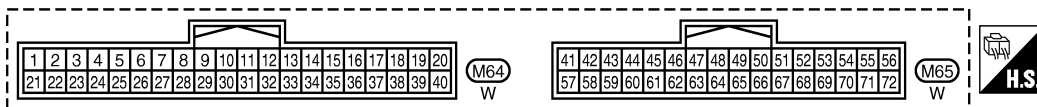

TKWT6856E



# WARNING LAMPS

< SERVICE INFORMATION >

DI-WARN-03

▬ : DATA LINE

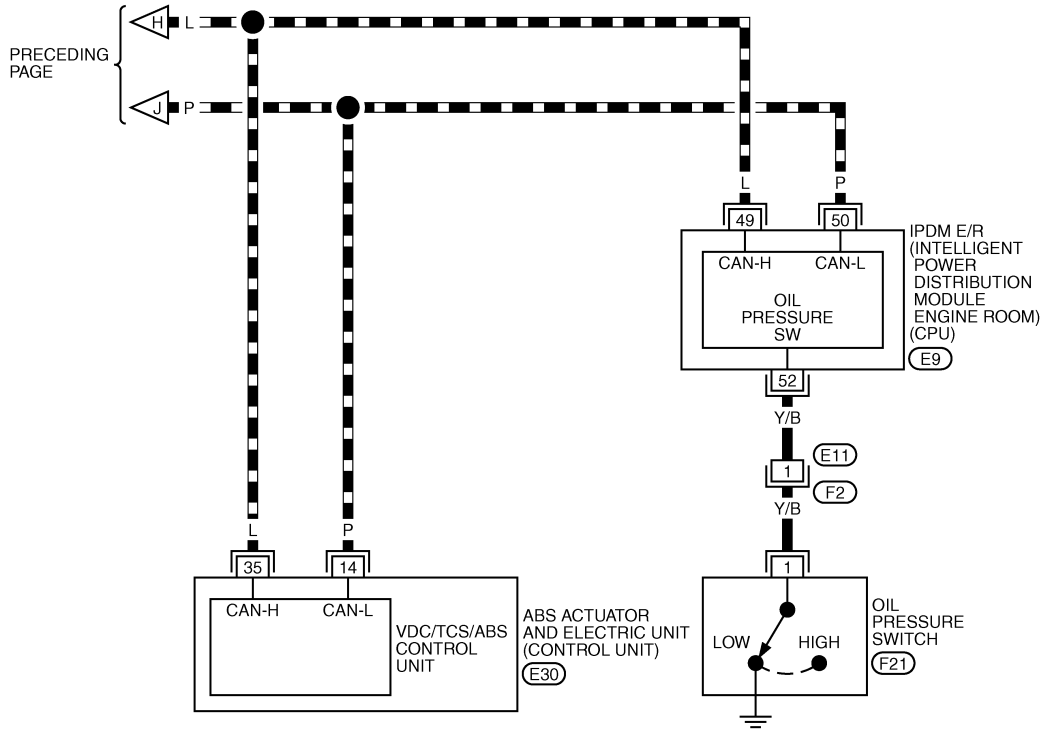
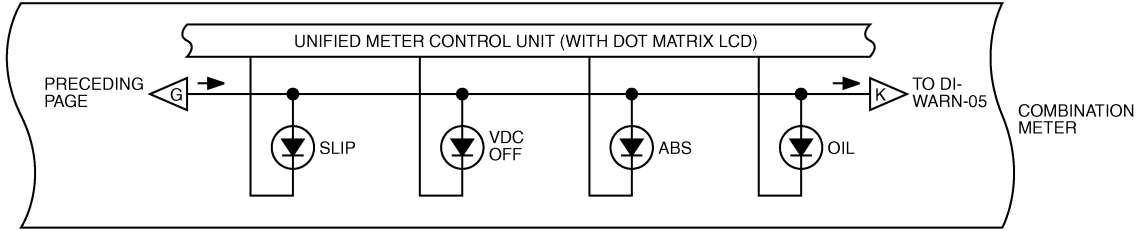

REFER TO THE FOLLOWING.  
(E30) -ELECTRICAL UNITS

TKWT3429E

A  
B  
C  
D  
E  
F  
G  
H  
I  
J  
DI  
L  
M  
N  
O  
P

# WARNING LAMPS

< SERVICE INFORMATION >

DI-WARN-04

▬ : DATA LINE

◊NV◊ : WITH NAVIGATION SYSTEM

◊ON◊ : WITHOUT NAVIGATION SYSTEM

◊LD◊ : WITH LANE DEPARTURE PREVENTION

\*1 52 : ◊NV◊ , 86 : ◊ON◊

\*2 53 : ◊NV◊ , 87 : ◊ON◊

\*3 102 : ◊NV◊ , 56 : ◊ON◊

\*4 103 : ◊NV◊ , 44 : ◊ON◊

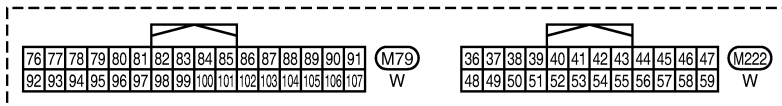
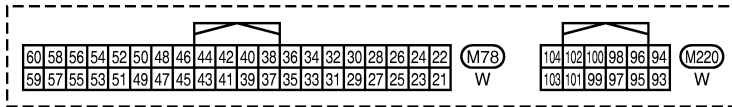
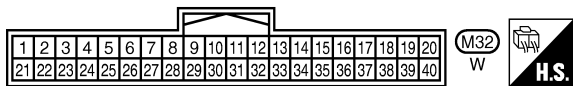
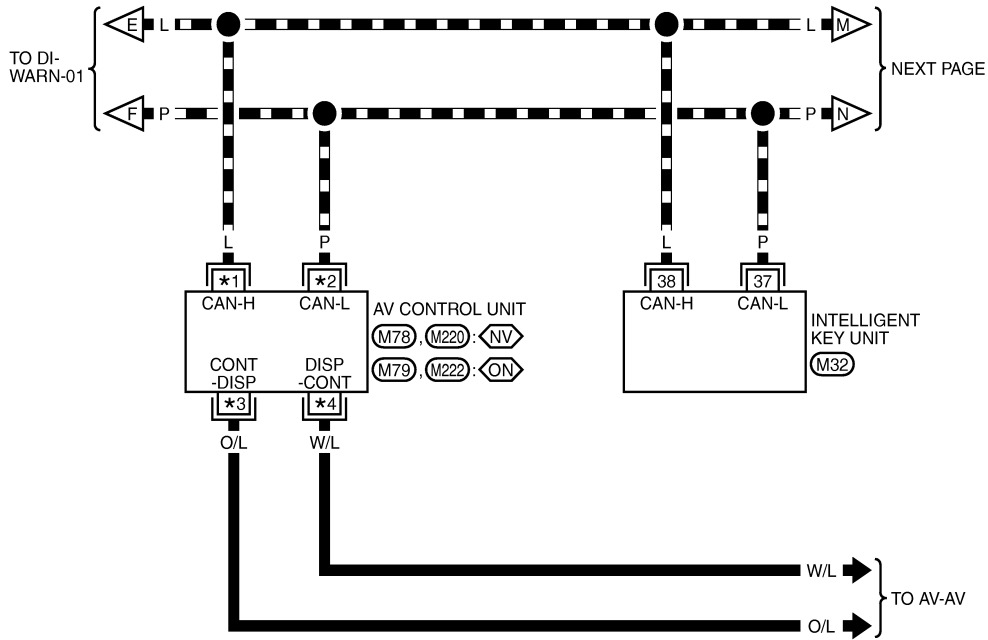
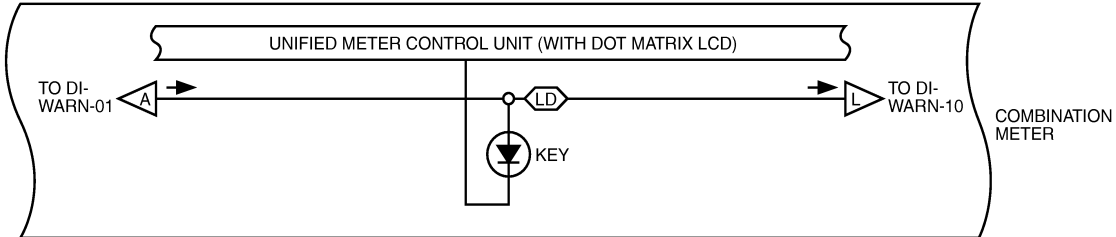

TKWT6858E



# WARNING LAMPS

< SERVICE INFORMATION >

DI-WARN-05

▬ : DATA LINE

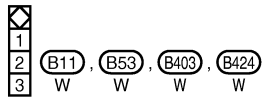
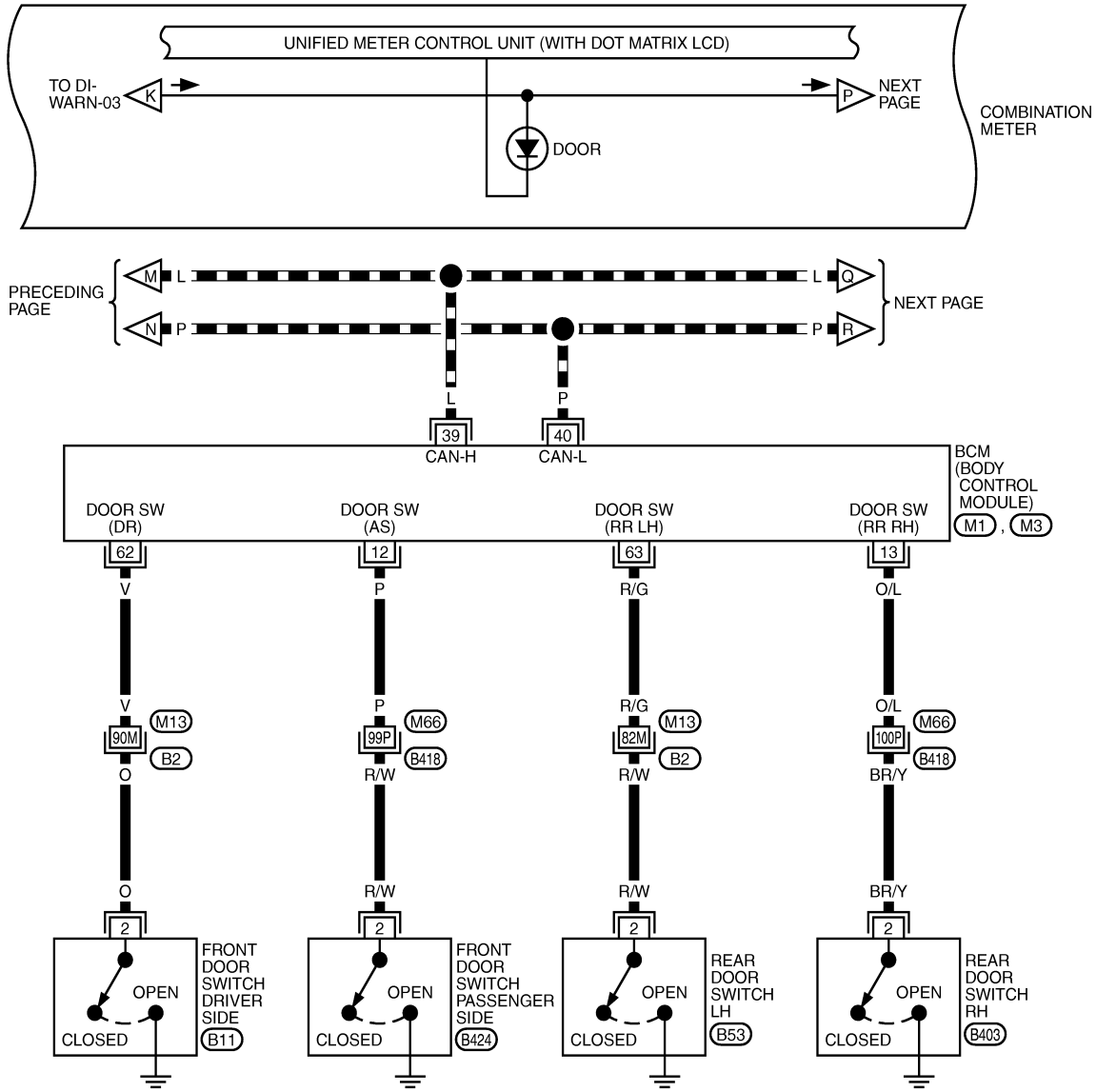

REFER TO THE FOLLOWING.  
 (B2) , (B418) - SUPER  
 MULTIPLE JUNCTION (SMJ)  
 (M1) , (M3) - ELECTRICAL  
 UNITS

TKWT6859E



A  
B  
C  
D  
E  
F  
G  
H  
I  
J  
K  
L  
M  
N  
O  
P

DI

# WARNING LAMPS

< SERVICE INFORMATION >

DI-WARN-06

 : DATA LINE  
 : AWD MODELS  
 : WITH AFS

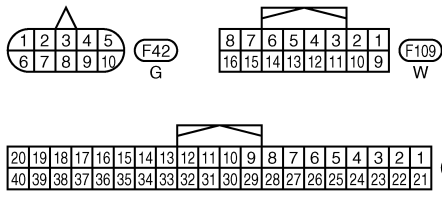
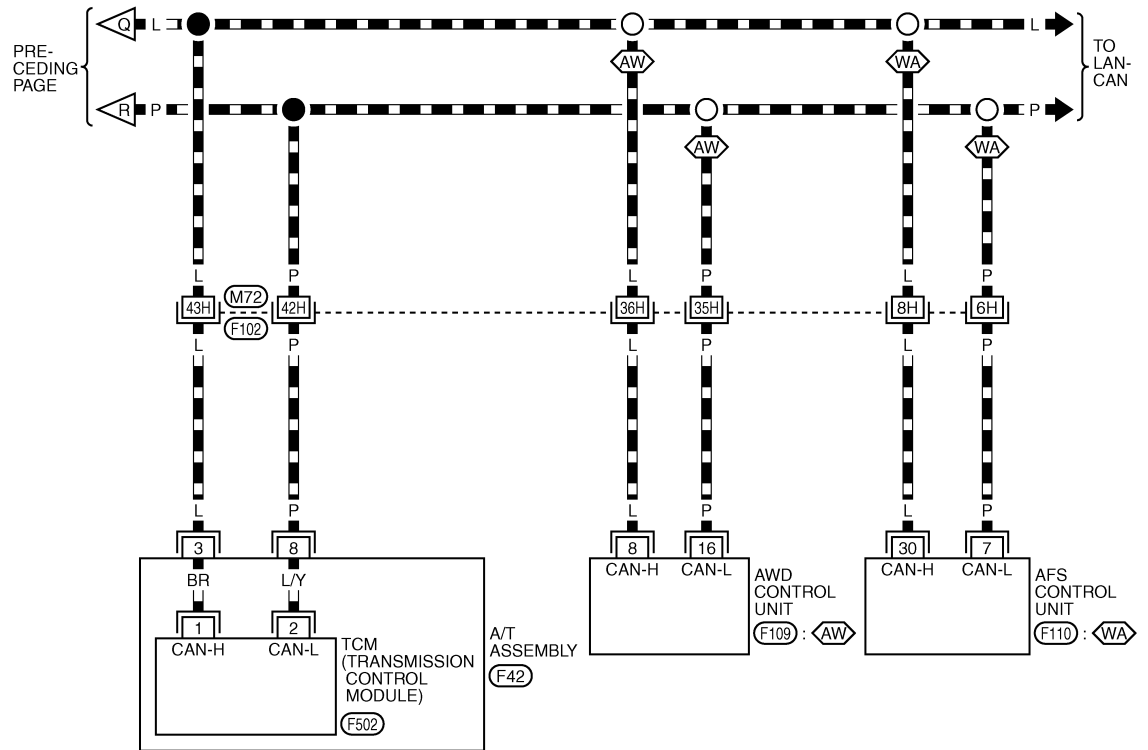
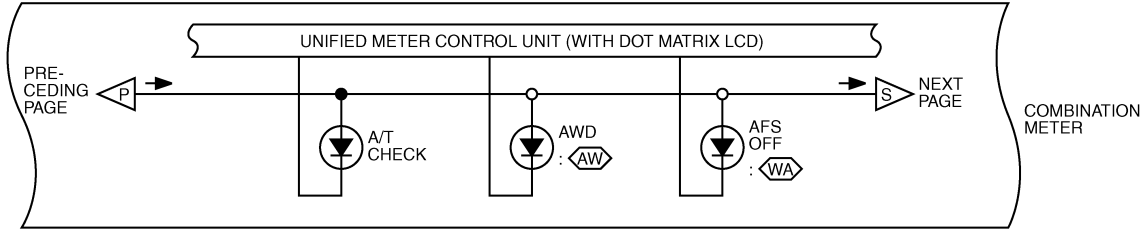

\*: THIS CONNECTOR IS NOT SHOWN IN "HARNESS LAYOUT", PG SECTION.

REFER TO THE FOLLOWING.  
 (F102) -SUPER MULTIPLE JUNCTION (SMJ)

TKWT3432E

# WARNING LAMPS

< SERVICE INFORMATION >

DI-WARN-07

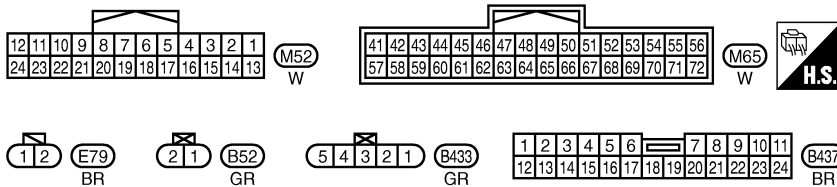
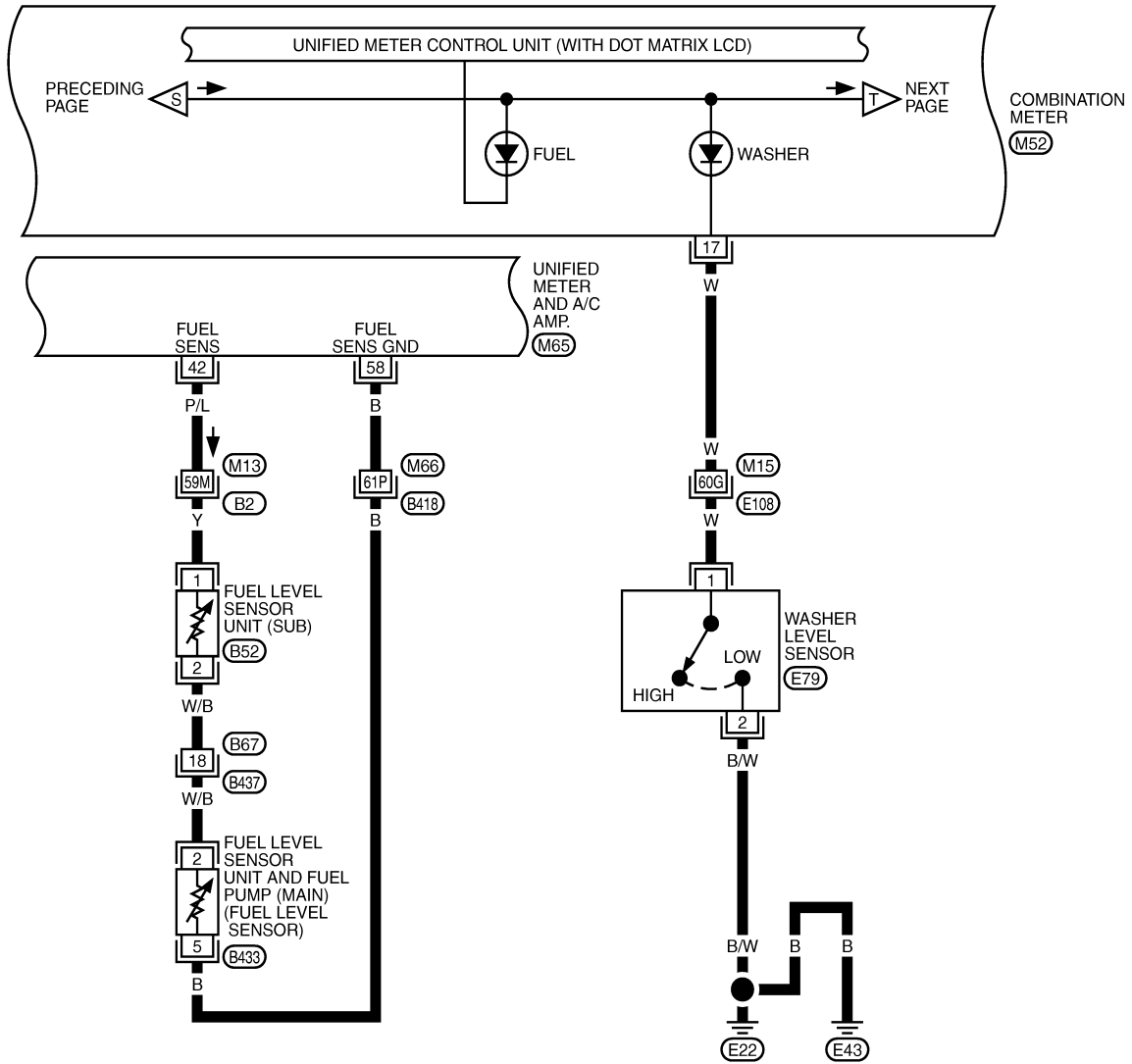

REFER TO THE FOLLOWING.  
 (E108), (B2), (B418) - SUPER  
 MULTIPLE JUNCTION (SMJ)

TKWT6860E

A  
B  
C  
D  
E  
F  
G  
H  
I  
J  
K  
L  
M  
N  
O  
P



# WARNING LAMPS

< SERVICE INFORMATION >

DI-WARN-08

⬡VK : WITH VK ENGINE

⬡VQ : WITH VQ ENGINE

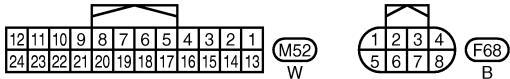
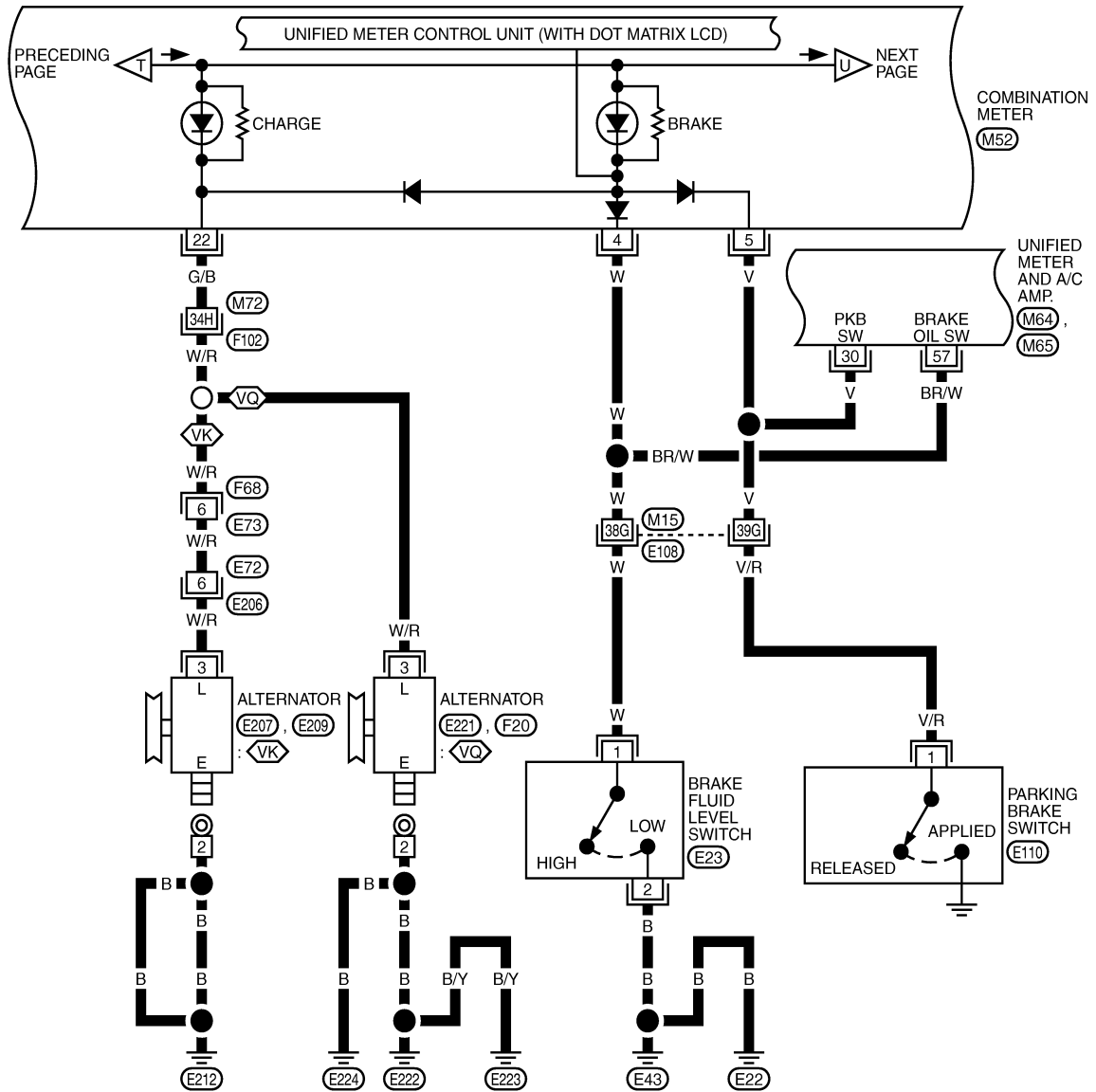

REFER TO THE FOLLOWING.  
 ⬡E108, ⬡F102 - SUPER MULTIPLE JUNCTION (SMJ)

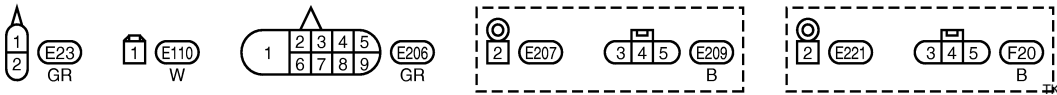
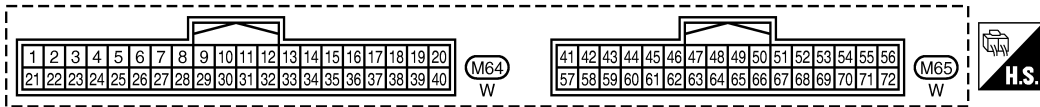

TKWT6861E

# WARNING LAMPS

< SERVICE INFORMATION >

DI-WARN-09

(AS) : WITH RAS

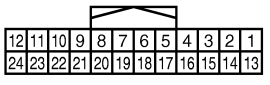
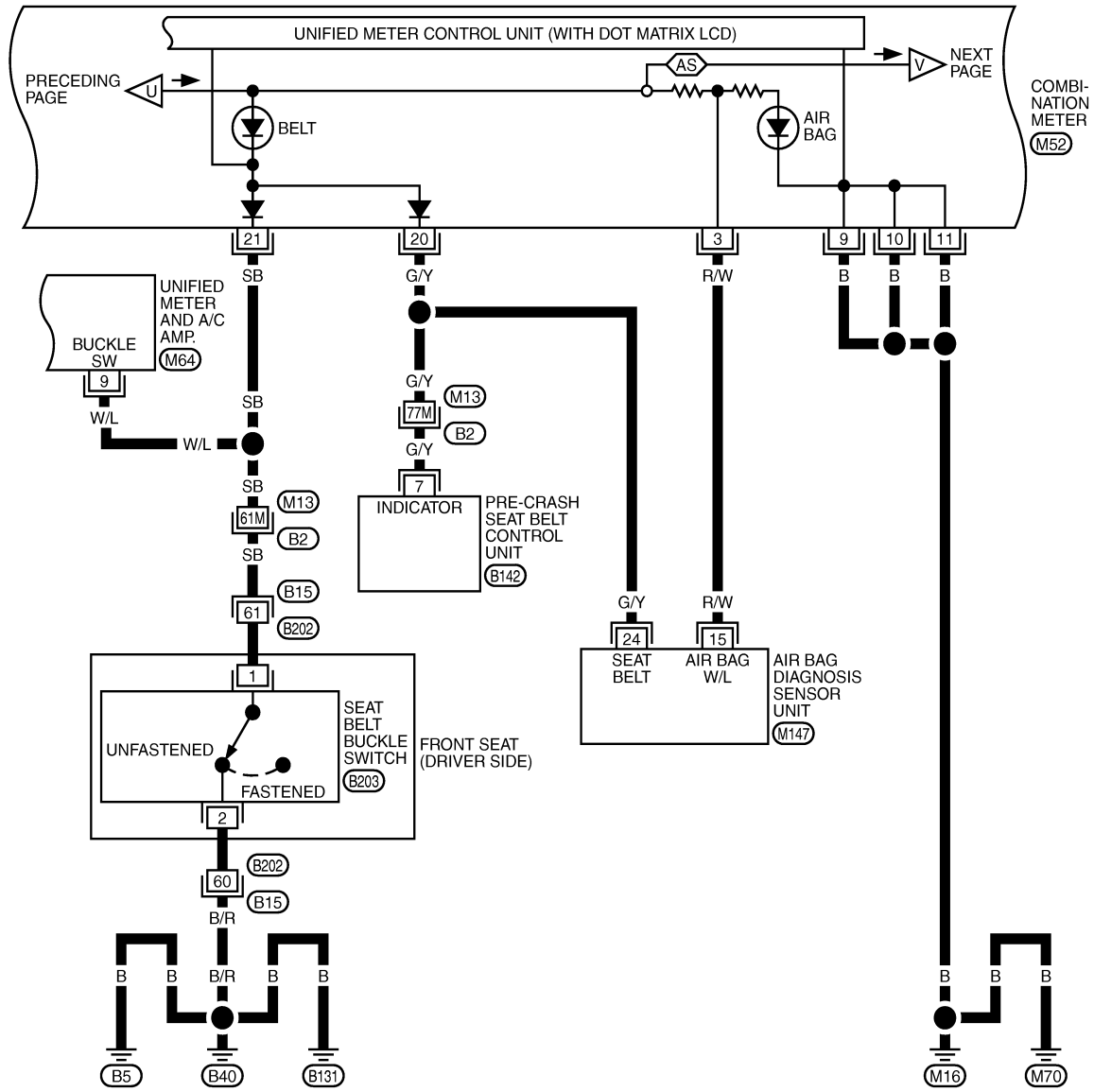

\*: THIS CONNECTOR IS NOT SHOWN IN "HARNES LAYOUT", PG SECTION.

REFER TO THE FOLLOWING.

(B2) - SUPER MULTIPLE JUNCTION (SMJ)

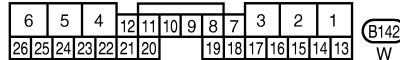
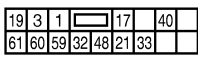
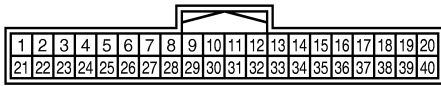

TKWT6862E

A  
B  
C  
D  
E  
F  
G  
H  
I  
J  
K  
L  
M  
N  
O  
P

DI

# WARNING LAMPS

< SERVICE INFORMATION >

DI-WARN-10

AS : WITH RAS

LD : WITH LANE DEPARTURE PREVENTION

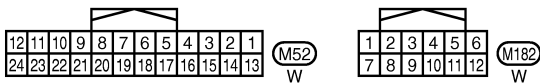
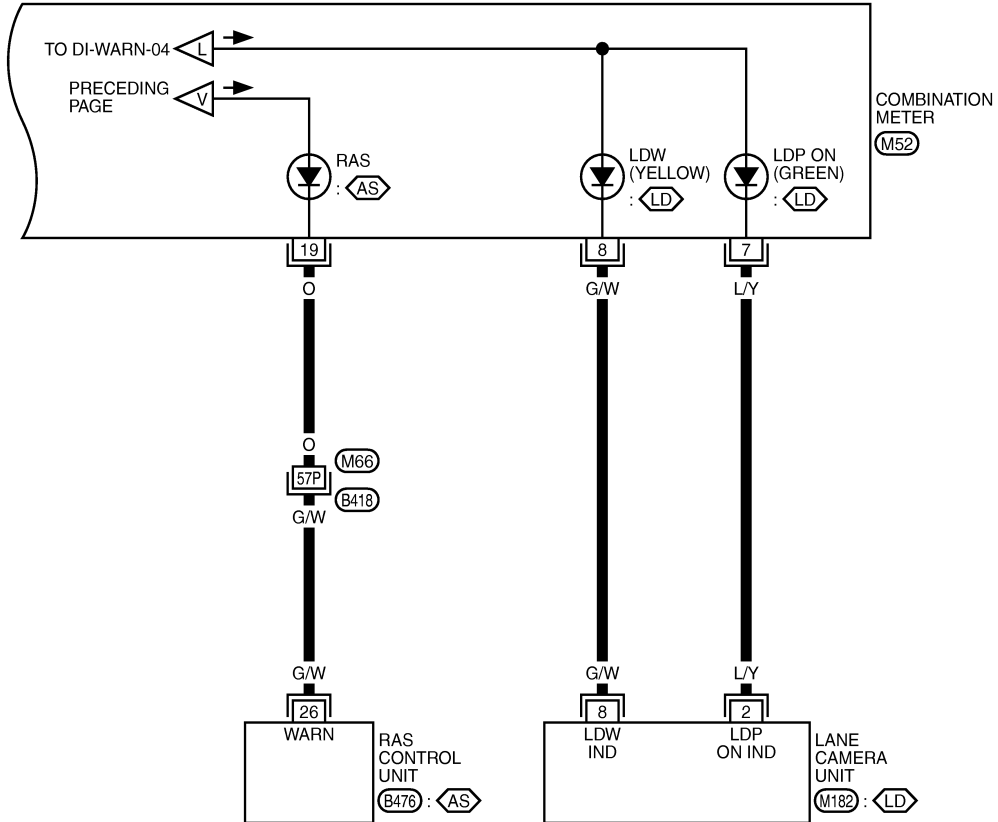

REFER TO THE FOLLOWING.

- (B418) - SUPER MULTIPLE JUNCTION (SMJ)
- (B476) - ELECTRICAL UNITS

TKWT6863E

INFOID:000000002956908

## Oil Pressure Warning Lamp Stays Off (Ignition Switch ON)

### 1. CHECK OPERATION OF OIL PRESSURE WARNING LAMP

Activate IPDM E/R auto active test. Refer to [PG-22. "Auto Active Test"](#).

Does oil pressure warning lamp is blinking?

- YES >> GO TO 2.
- NO >> GO TO 4.

# WARNING LAMPS

< SERVICE INFORMATION >

## 2. CHECK OIL PRESSURE SWITCH CIRCUIT

1. Turn ignition switch OFF.
2. Disconnect IPDM E/R connector and oil pressure switch connector.
3. Check continuity between IPDM E/R harness connector (A) and oil pressure switch harness connector (B).

| A         |          | B         |          | Continuity |
|-----------|----------|-----------|----------|------------|
| Connector | Terminal | Connector | Terminal |            |
| E9        | 52       | F21       | 1        | Yes        |

OK or NG

- OK >> GO TO 3.  
NG >> Repair harness or connector.

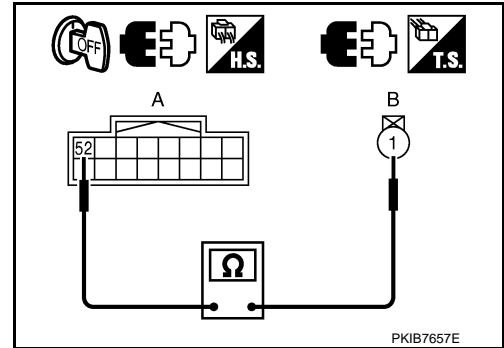

## 3. CHECK OIL PRESSURE SWITCH

Check oil pressure switch. Refer to [DI-48, "Electrical Component Inspection"](#).

OK or NG

- OK >> Replace IPDM E/R. Refer to [PG-27, "Removal and Installation of IPDM E/R"](#).  
NG >> Replace oil pressure switch.

## 4. CHECK UNIFIED METER AND A/C AMP. (CONSULT-III)

Perform self-diagnosis of unified meter and A/C amp. Refer to [DI-27, "CONSULT-III Function \(METER/M&A\)"](#).

Self-diagnostic results content

- No malfunction detected >> GO TO 5.  
Malfunction detected >> Check applicable parts, and repair or replace corresponding parts.

## 5. CHECK UNIFIED METER AND A/C AMP. INPUT SIGNAL

1. Select "METER/M&A" on CONSULT-III.
2. Operate ignition switch with "OIL W/L" of "Data Monitor" and check operation status.

**"OIL W/L"**

**When ignition switch is in ON : On**  
**position (Engine stopped)**

**When engine running : Off**

OK or NG

- OK >> Replace combination meter.  
NG >> GO TO 6.

## 6. CHECK BCM INPUT SIGNAL

1. Select "SIGNAL BUFFER" of "BCM" on CONSULT-III.
2. Operate ignition switch with "OIL PRESS SW" of "Data Monitor" and check operate status.

**"OIL PRESS SW"**

**When ignition switch is in ON : On**  
**position (Engine stopped)**

**When engine running : Off**

OK or NG

- OK >> Replace BCM. Refer to [BCS-14, "Removal and Installation of BCM"](#).  
NG >> Replace IPDM E/R. Refer to [PG-27, "Removal and Installation of IPDM E/R"](#).

Oil Pressure Warning Lamp Does Not Turn Off (Oil Pressure Is Normal)

INFOID:000000002956909

**NOTE:**

For oil pressure inspection, refer to [LU-5, "Inspection"](#) (VQ35DE) or [LU-23, "Inspection"](#) (VK45DE).

# WARNING LAMPS

## < SERVICE INFORMATION >

### 1. CHECK OPERATION OF OIL PRESSURE WARNING LAMP

Activate IPDM E/R auto active test. Refer to [PG-22. "Auto Active Test"](#).

Does oil pressure warning lamp is blinking?

- YES >> GO TO 2.
- NO >> GO TO 5.

### 2. CHECK IPDM E/R OUTPUT SIGNAL

1. Turn ignition switch OFF.
2. Disconnect oil pressure switch connector.
3. Turn ignition switch ON.
4. Check voltage between oil pressure switch harness connector and ground.

| Terminals                     |          |        | Voltage (Approx.) |
|-------------------------------|----------|--------|-------------------|
| (+)                           |          | (-)    |                   |
| Oil pressure switch connector | Terminal |        |                   |
| F21                           | 1        | Ground | 12 V              |

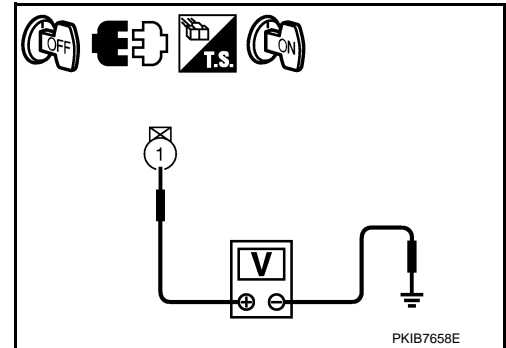

OK or NG

- OK >> GO TO 3.
- NG >> GO TO 4.

### 3. CHECK OIL PRESSURE SWITCH

1. Turn ignition switch OFF.
2. Check oil pressure switch. Refer to [DI-48. "Electrical Component Inspection"](#).

OK or NG

- OK >> Replace IPDM E/R. Refer to [PG-27. "Removal and Installation of IPDM E/R"](#).
- NG >> Replace oil pressure switch.

### 4. CHECK OIL PRESSURE SWITCH CIRCUIT

1. Turn ignition switch OFF.
2. Disconnect IPDM E/R connector.
3. Check continuity between IPDM E/R harness connector and ground.

| IPDM E/R connector | Terminal | Ground | Continuity |
|--------------------|----------|--------|------------|
| E9                 | 52       |        | No         |

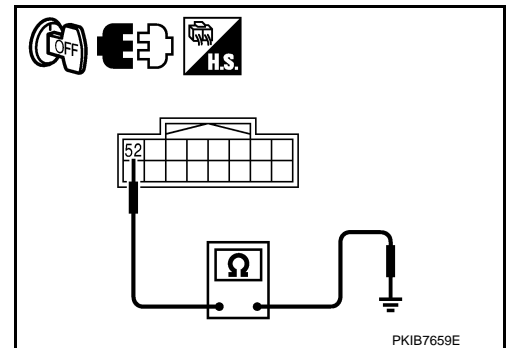

OK or NG

- OK >> Replace IPDM E/R. Refer to [PG-27. "Removal and Installation of IPDM E/R"](#).
- NG >> Repair harness or connector.

### 5. CHECK IPDM E/R (CONSULT-III)

Perform self-diagnosis of IPDM E/R. Refer to [PG-20. "CONSULT-III Function \(IPDM E/R\)"](#).

Self-diagnostic results content

- No malfunction detected>> Replace combination meter.
- Malfunction detected>> Check applicable parts, and repair or replace corresponding parts.

## Electrical Component Inspection

INFOID:000000002956910

## OIL PRESSURE SWITCH



# WARNING LAMPS

## < SERVICE INFORMATION >

Check continuity between oil pressure switch and ground.

| Condition      | Continuity |
|----------------|------------|
| Engine stopped | Yes        |
| Engine running | No         |

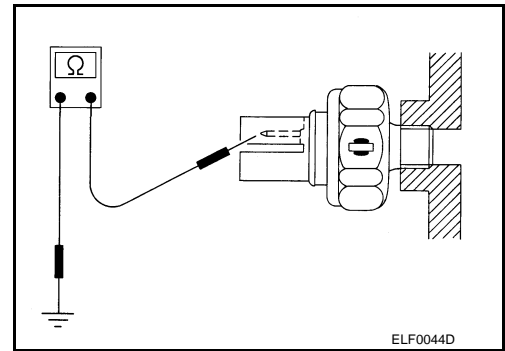

A  
B  
C  
D  
E  
F  
G  
H  
I  
J  
DI  
L  
M  
N  
O  
P

# A/T INDICATOR

< SERVICE INFORMATION >

## A/T INDICATOR

### System Description

INFOID:000000002956911

A/T shift position is displayed in the dot matrix LCD in the combination meter.

#### MANUAL MODE

- Unified meter and A/C amp. inputs manual mode signal and shift-up/down signal from A/T shift selector (manual mode switch), and transmits the signals to TCM with CAN communication.
- TCM processes manual mode signal and shift-up/down signal, and transmits manual mode indicator signal and shift position indicator signal to unified meter and A/C amp. with CAN communication.
- Unified meter and A/C amp. transmits manual mode indicator signal and shift position indicator signal to combination meter with the communication line.
- Combination meter indicates A/T shift position and manual mode indicator, when receiving manual mode indicator signal and shift position indicator signal.

#### NOT MANUAL MODE

- Unified meter and A/C amp. inputs not manual mode signal from A/T shift selector (manual mode switch), and transmits the signals to TCM with CAN communication.
- TCM transmits shift position indicator signal to unified meter and A/C amp. with CAN communication.
- Unified meter and A/C amp. transmits shift position indicator signal to combination meter with the communication line.
- Combination meter indicates A/T shift position when receiving shift position indicator signal.

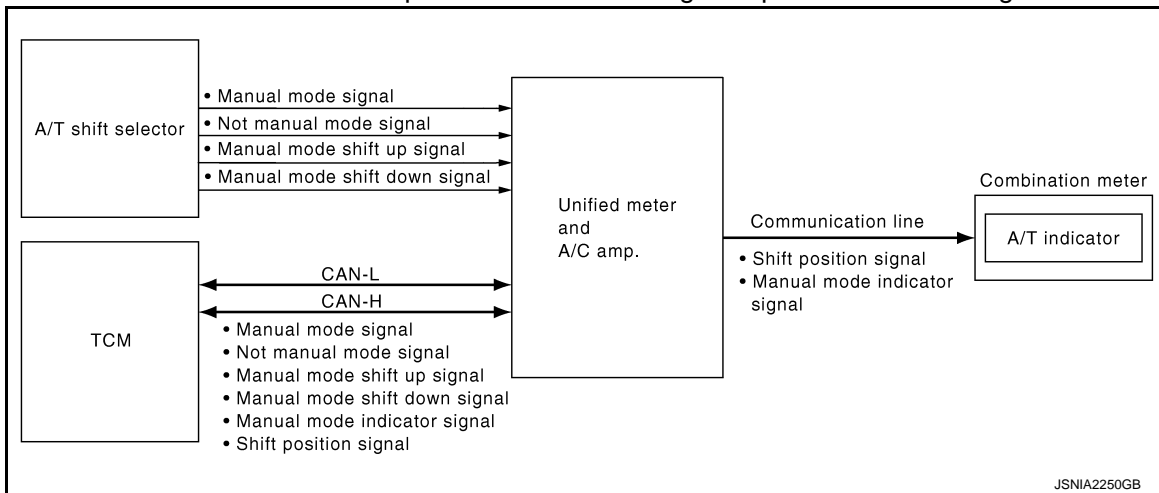

# A/T INDICATOR

< SERVICE INFORMATION >

## Wiring Diagram - AT/IND -

INFOID:00000002956912

### DI-AT/IND-01

▬ : DATA LINE

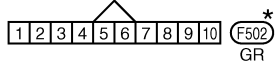
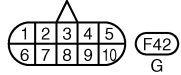
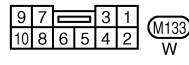
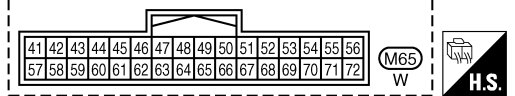
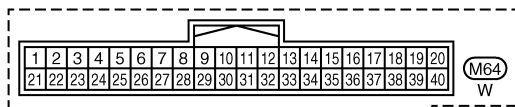
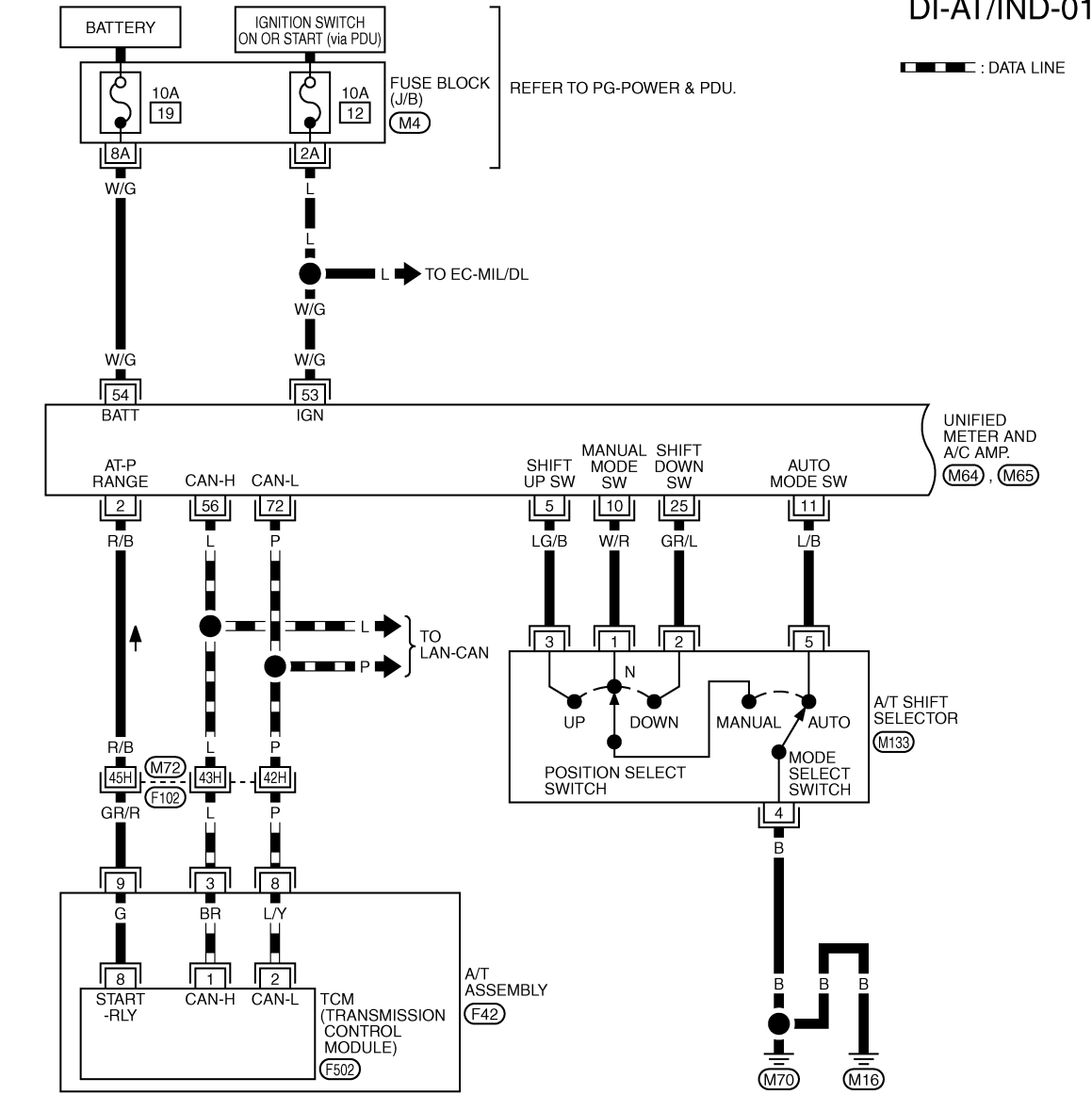

\*: THIS CONNECTOR IS NOT SHOWN IN "HARNESS LAYOUT", PG. SECTION.

REFER TO THE FOLLOWING.  
 (F102) - SUPER MULTIPLE JUNCTION (SMJ)  
 (M4) - FUSE BLOCK-JUNCTION BOX (J/B)

TKWM6097E

# A/T INDICATOR

< SERVICE INFORMATION >

DI-AT/IND-02

⬠VK : WITH VK ENGINE

⬠VQ : WITH VQ ENGINE

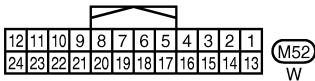
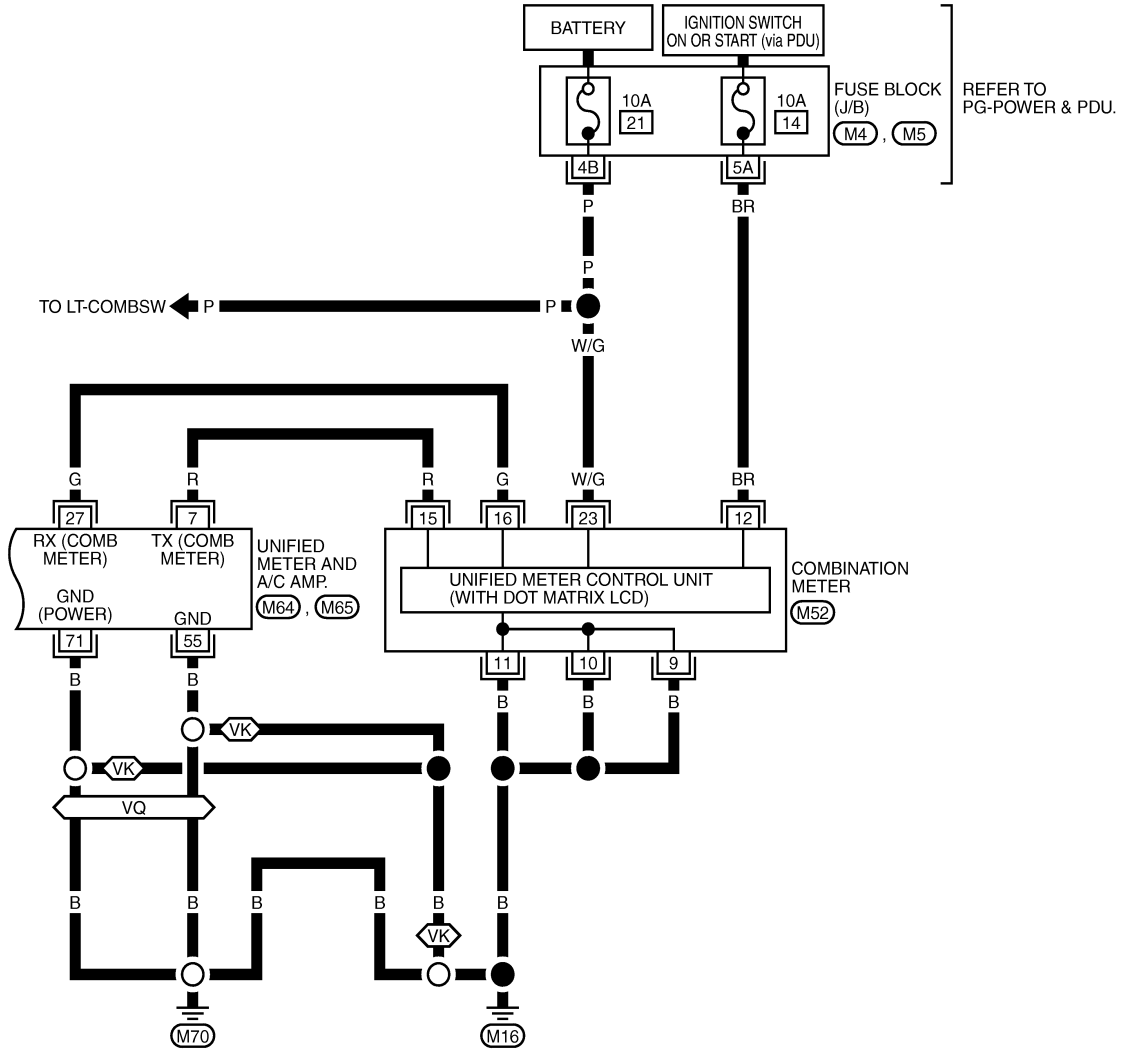

REFER TO THE FOLLOWING.

⬠M4, ⬠M5 - FUSE BLOCK - JUNCTION BOX (J/B)

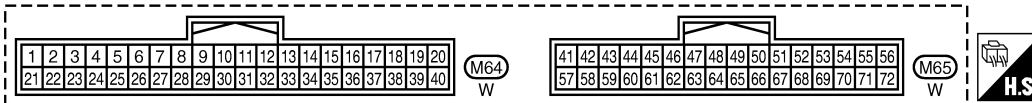

TKWT7186E

INFOID:000000003301995

## A/T Indicator Is Malfunction

### 1. CHECK SEGMENTS OF A/T INDICATOR

Perform self-diagnosis mode of combination meter. Refer to [DI-17. "Self-Diagnosis Mode of Combination Meter"](#).

Are all segments displayed?

YES >> GO TO 2.

# A/T INDICATOR

## < SERVICE INFORMATION >

NO >> Replace combination meter.

### 2.CHECK UNIFIED METER AND A/C AMP. (CONSULT-III)

Perform self-diagnosis of unified meter and A/C amp. Refer to [DI-27, "CONSULT-III Function \(METER/M&A\)"](#).

#### Self-diagnosis results

No malfunction detected >> GO TO 3.

Malfunction detected >> Check applicable parts, and repair or replace corresponding parts.

### 3.CHECK UNIFIED METER AND A/C AMP. INPUT SIGNAL

Use "Data Monitor" of "METER/M&A" on CONSULT-III. Confirm each indication on the monitor when operating the shift lever.

| CONSULT-III display | Switch operation                      | Operation status |
|---------------------|---------------------------------------|------------------|
| AT-M IND            | Manual mode range                     | On               |
|                     | Except for manual mode range          | Off              |
| AT-M GEAR           | Manual mode range (shift- up or down) | 5 - 1            |
|                     | Except for manual mode range          | 1                |
| P RANGE IND         | P range position                      | On               |
|                     | Except for P range position           | Off              |
| R RANGE IND         | R range position                      | On               |
|                     | Except for R range position           | Off              |
| N RANGE IND         | N range position                      | On               |
|                     | Except for N range position           | Off              |
| D RANGE IND         | D range position                      | On               |
|                     | Except for D range position           | Off              |

#### OK or NG

OK >> Replace combination meter.

NG >> GO TO 4.

### 4.CHECK TCM (CONSULT-III)

Perform self-diagnosis of TCM. Refer to [AT-85, "CONSULT-III Function \(TRANSMISSION\)"](#).

#### Self-diagnosis results

No malfunction detected >> Check TCM input/output signal. Refer to [AT-33, "Input/Output Signal of TCM"](#).

Malfunction detected >> Check applicable part, and repair or replace corresponding parts.

A  
B  
C  
D  
E  
F  
G  
H  
I  
J  
DI  
L  
M  
N  
O  
P

# WARNING CHIME

< SERVICE INFORMATION >

## WARNING CHIME

### System Description

INFOID:000000002956914

- The buzzer (1) for warning chime system is installed in the combination meter.
- The buzzer sounds when the combination meter receives buzzer output signal from each unit through unified meter and A/C amp.

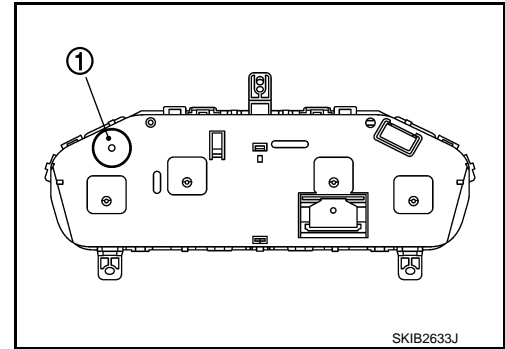

### POWER SUPPLY AND GROUND CIRCUIT

Power is supplied at all times

- through 50A fusible link (letter **F**, located in the fuse and fusible link block)
- to BCM terminal 55,
- through 10A fuse [No. 21, located in the fuse block (J/B)]
- to BCM terminal 42, and
- to combination meter terminal 23,
- through 10A fuse [No. 19, located in the fuse block (J/B)]
- to unified meter and A/C amp. terminal 54.

When ignition switch is in ON or START position, power is supplied

- through 15A fuse [No. 1, located in the fuse block (J/B)]
- to BCM terminal 38,
- through 10A fuse [No. 12, located in the fuse block (J/B)]
- to unified meter and A/C amp. terminal 53,
- through 10A fuse [No. 14, located in the fuse block (J/B)]
- to combination meter terminal 12.

Ground is supplied

- to BCM terminals 52,
- to unified meter and A/C amp. terminals 55 and 71, and
- to combination meter terminals 9, 10 and 11,
- through grounds M16 and M70.

### IGNITION KEY WARNING CHIME (WITH INTELLIGENT KEY)

Refer to [BL-43. "System Description"](#) in intelligent key system.

### LIGHT WARNING CHIME

With ignition switch in OFF or ACC position, driver door open, and lighting switch in 1ST or 2ND position, the light warning chime will sound.

- BCM detects ignition switch in OFF or ACC position, front door switch (driver side) ON, and lighting switch in 1ST or 2ND position. And then transmits buzzer output signal (light warning chime) to unified meter and A/C amp. with CAN communication line.
- Unified meter and A/C amp. transmits buzzer output signal (light warning chime) to combination meter with communication line.
- When combination meter receives buzzer output signal (light warning chime), it sounds the buzzer.

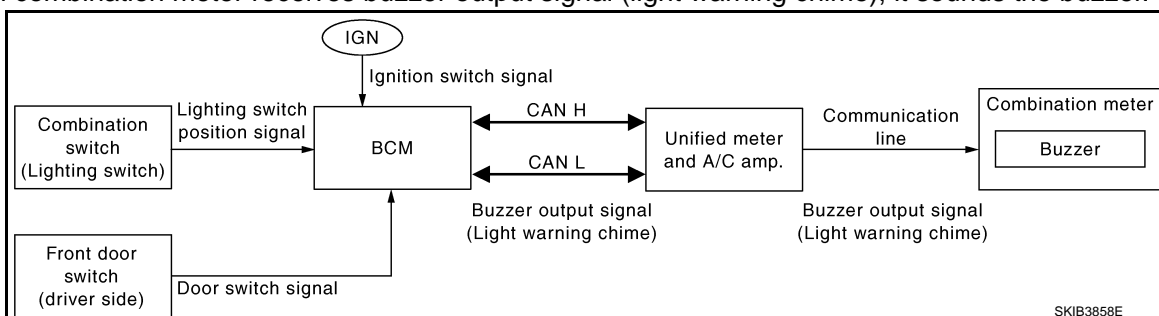

**NOTE:**

SKIB3858E

# WARNING CHIME

## < SERVICE INFORMATION >

For further details of combination switch, refer to [BCS-4. "System Description"](#).

### SEAT BELT WARNING CHIME

With ignition switch turned ON and driver seat belt unfastened, seat belt warning chime will sound for approximately 6 seconds.

- BCM receives seat belt buckle switch signal [seat belt buckle switch (driver side) ON] from unified meter and A/C amp. with CAN communication line.
- BCM detects ignition switch turned ON and seat belt buckle switch (driver side) ON. And then transmits buzzer output signal (seat belt warning chime) to unified meter and A/C amp. with CAN communication line.
- Unified meter and A/C amp. transmits buzzer output signal (seat belt warning chime) to combination meter with communication line.
- When combination meter receives buzzer output signal (seat belt warning chime), it sounds the buzzer.

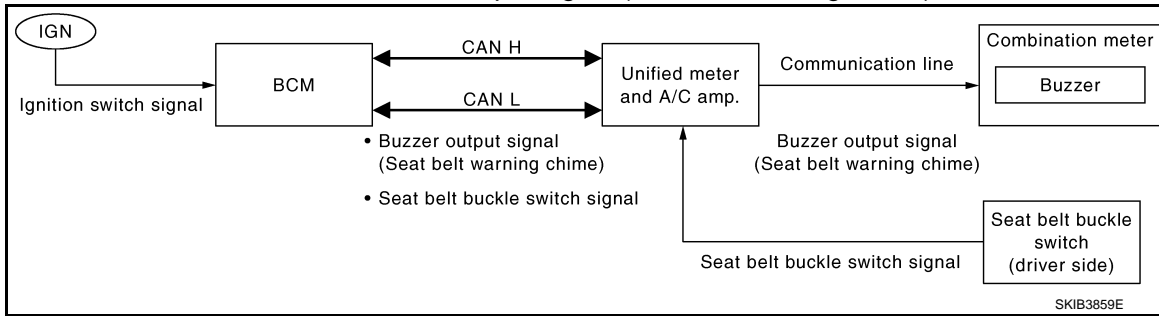

### PARKING BRAKE RELEASE WARNING CHIME

The parking brake warning chime sounds when the parking brake is applied and vehicle speed reaches approximately 7 km/h (4.3 MPH) or higher.

- The combination meter receives a parking brake applied signal from the parking brake switch.
- The unified meter and A/C amp. receives the vehicle speed signal from the ABS actuator and electric unit (control unit) via CAN communication line and transmits it to the combination meter by means of communication line.

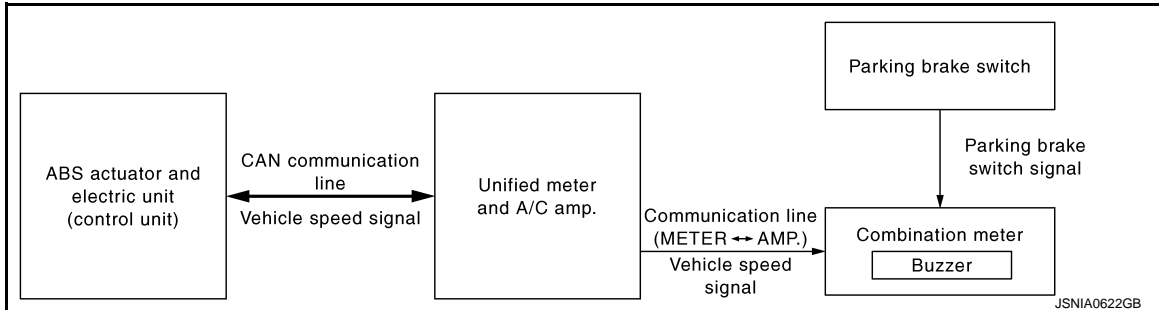

# WARNING CHIME

< SERVICE INFORMATION >

## Component Parts and Harness Connector Location

INFOID:000000002956915

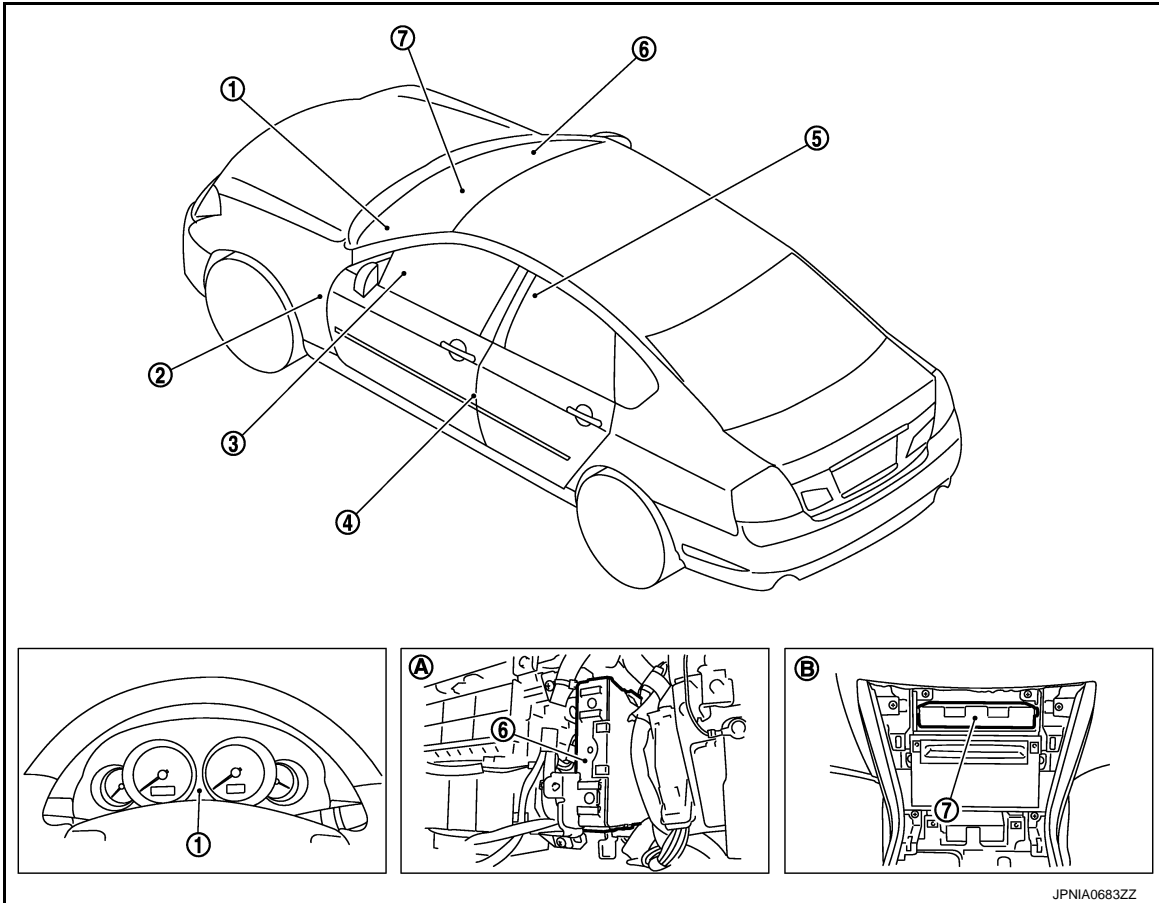

JPNIA0683ZZ

- |                                    |  |   |
|------------------------------------|--|---|
| 1. Combination meter               | 2. Parking brake switch                  | 3. Combination switch (Lighting switch) |
| 4. Front door switch (Driver side) | 5. Seat belt buckle switch (Driver side) | 6. BCM                                  |
| 7. Unified meter and A/C amp.      |  |   |
| A. View with glove box removed.    | B. View with cluster lid C removed.      |   |



# WARNING CHIME

< SERVICE INFORMATION >

## Schematic

INFOID:000000002956916

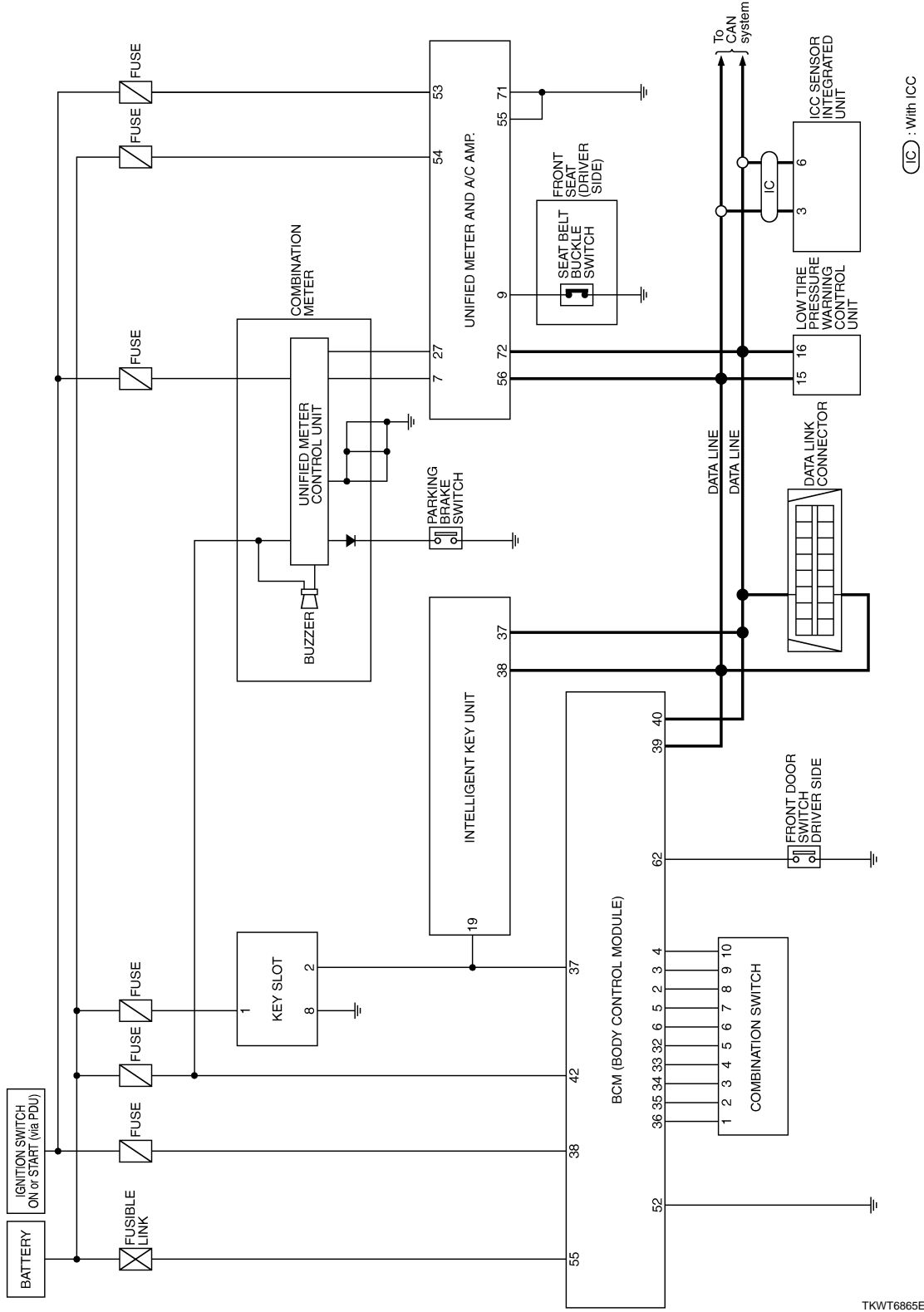

(IC) : With ICC

A  
B  
C  
D  
E  
F  
G  
H  
I  
J  
**DI**  
L  
M  
N  
O  
P

# WARNING CHIME

< SERVICE INFORMATION >

## Wiring Diagram - CHIME -

INFOID:00000002956917

### DI-CHIME-01

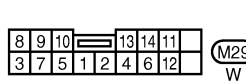
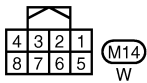
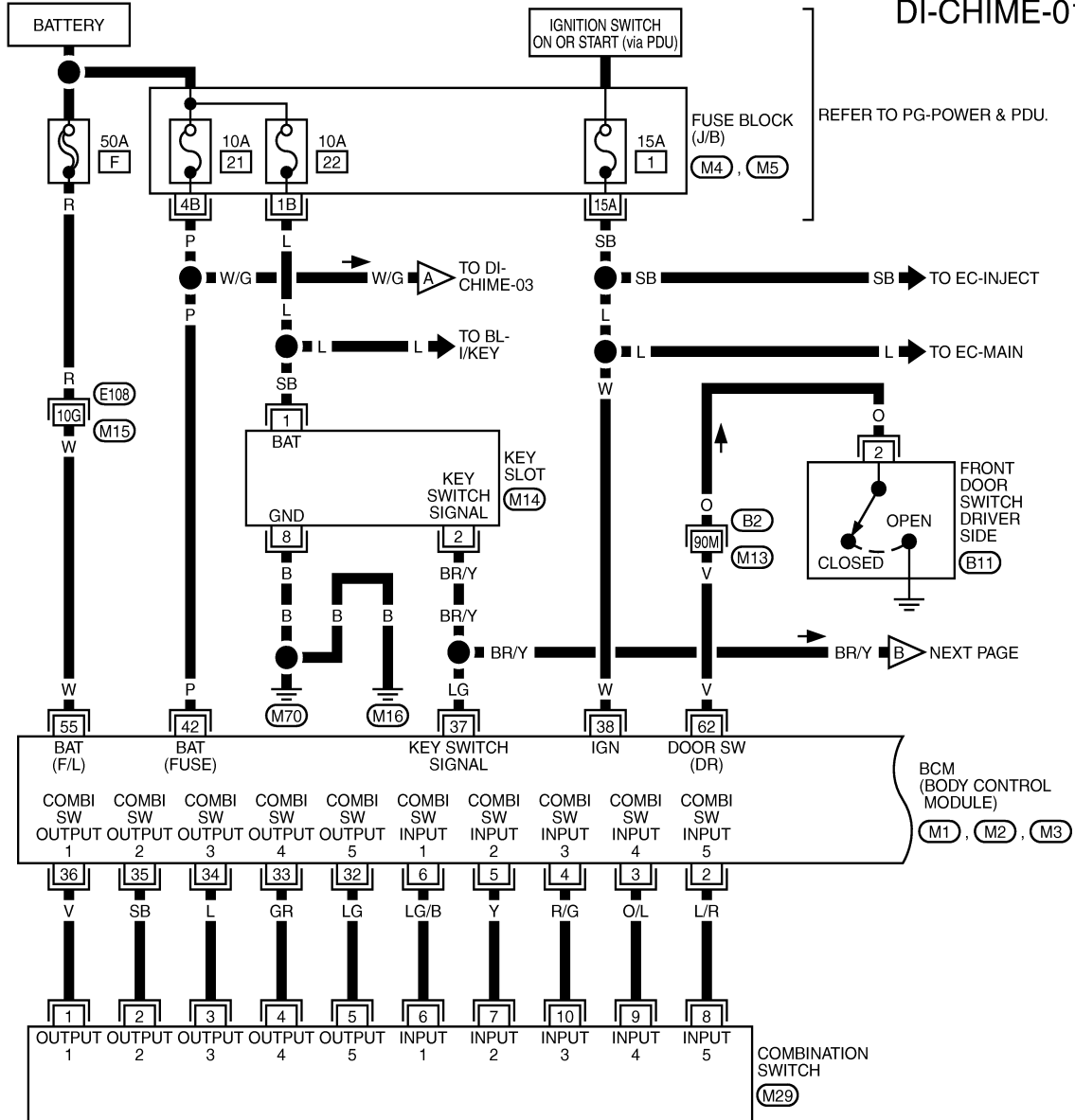

REFER TO THE FOLLOWING.  
 (E108), (B2) - SUPER MULTIPLE JUNCTION (SMJ)  
 (M4), (M5) - FUSE BLOCK - JUNCTION BOX (J/B)  
 (M1), (M2), (M3) - ELECTRICAL UNITS

TKWT6866E

# WARNING CHIME

< SERVICE INFORMATION >

DI-CHIME-02

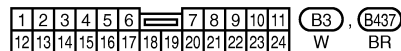
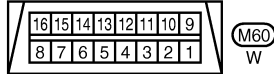
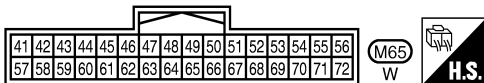
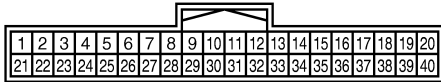
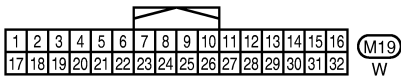
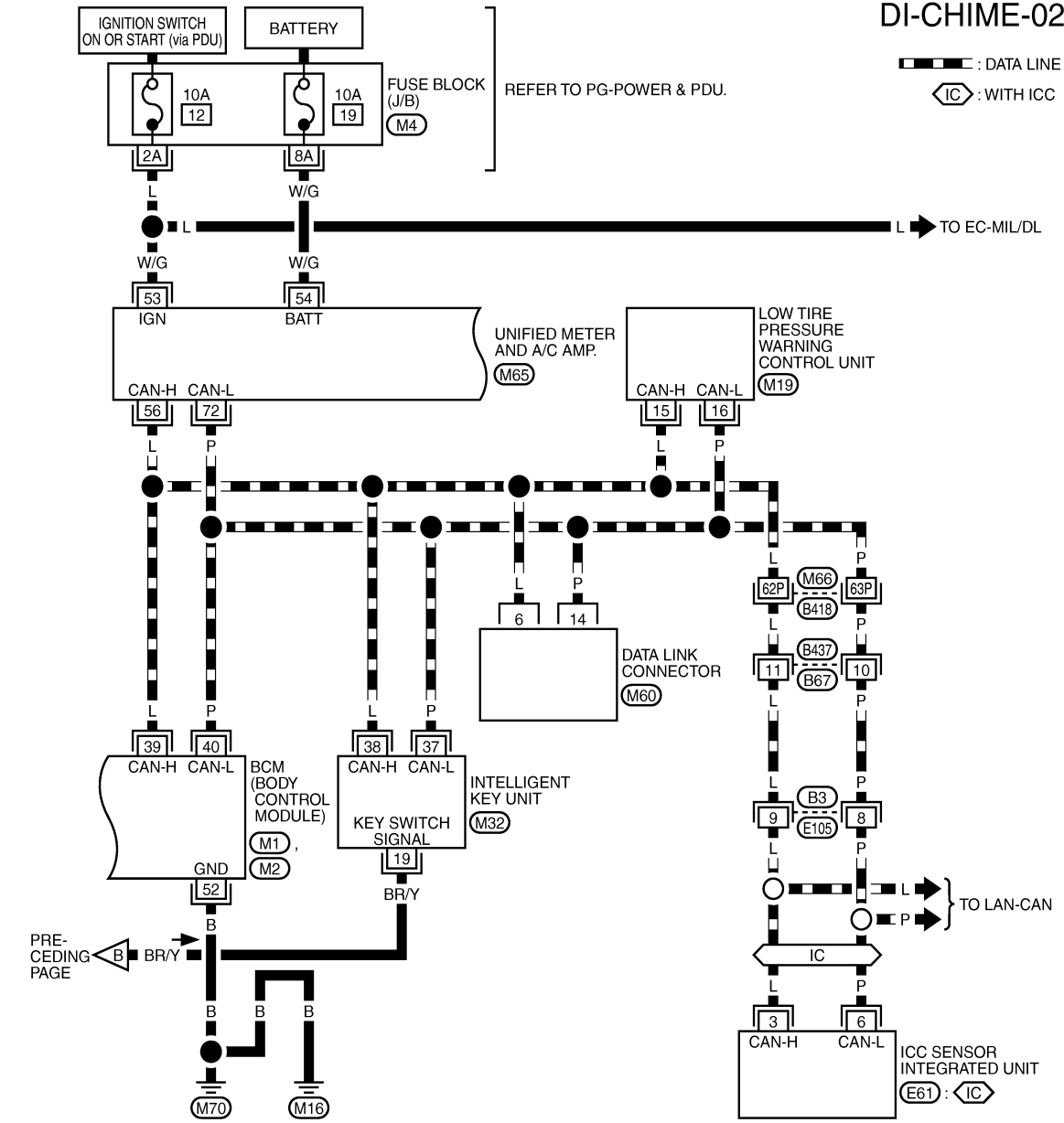

REFER TO THE FOLLOWING.  
 (B418) - SUPER MULTIPLE JUNCTION (SMJ)  
 (M4) - FUSE BLOCK - JUNCTION BOX (J/B)  
 (M1), (M2) - ELECTRICAL UNITS

TKWT6867E

A  
B  
C  
D  
E  
F  
G  
H  
I  
J  
DI  
L  
M  
N  
O  
P

# WARNING CHIME

< SERVICE INFORMATION >

DI-CHIME-03

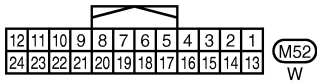
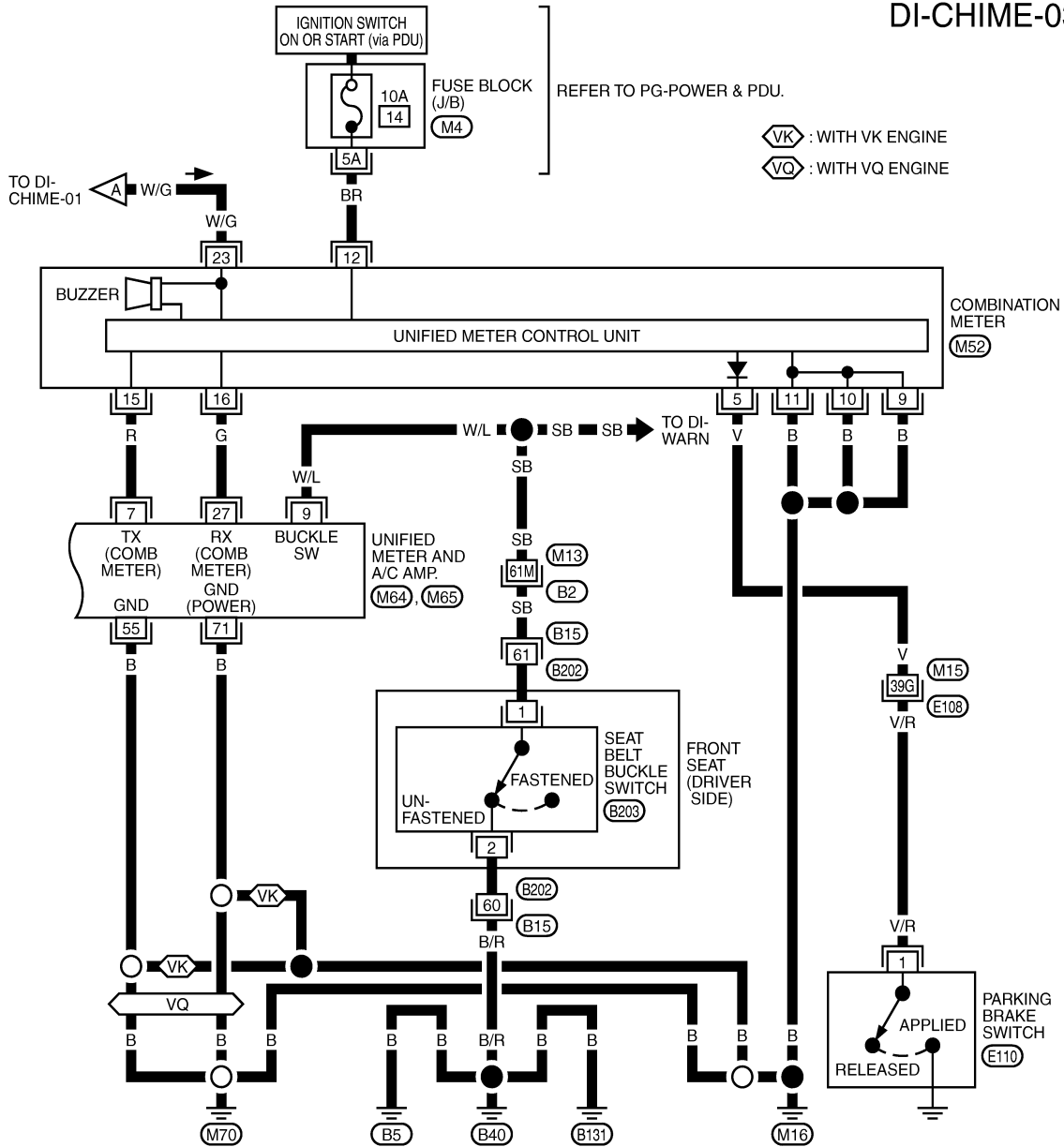

REFER TO THE FOLLOWING.  
 (E108), (B2) - SUPER MULTIPLE JUNCTION (SMJ)  
 (M4) - FUSE BLOCK - JUNCTION BOX (J/B)

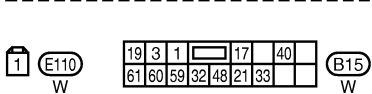
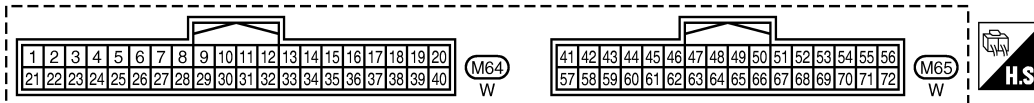

\* : THIS CONNECTOR IS NOT SHOWN IN "HARNESS LAYOUT", PG SECTION.



TKWT6868E

# WARNING CHIME

< SERVICE INFORMATION >

## Terminal and Reference Value for Combination Meter

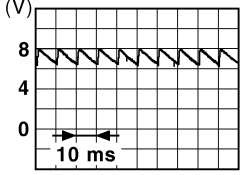
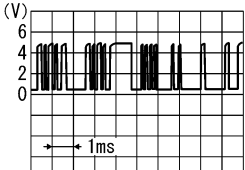
INFOID:000000002956918

| Terminal No. | Wire color | Item  | Condition       |                        | Reference value (Approx.)   |
|--------------|------------|---|-----------------|------------------------|---|
|              |            |   | Ignition switch | Operation or condition |   |
| 5            | V          | Parking brake switch signal                             | ON              | Parking brake applied  | 0 V   |
|              |            |   |                 | Parking brake released |  <p style="text-align: right; font-size: small;">JSNIA0007GB</p> |
| 9            | B          | Ground  | ON              | —                      | 0 V   |
| 10           |            |   |                 |                        |   |
| 11           |            |   |                 |                        |   |
| 12           | BR         | Ignition switch ON or START                             | ON              | —                      | Battery voltage   |
| 15           | R          | RX communication line (From unified meter and A/C amp.) | ON              | —                      |  <p style="text-align: right; font-size: small;">SKIA3362E</p>  |
| 16           | G          | TX communication line (To unified meter and A/C amp.)   | ON              | —                      |  <p style="text-align: right; font-size: small;">SKIA3361E</p> |
| 23           | W/G        | Battery power supply                                    | OFF             | —                      | Battery voltage   |

## Terminal and Reference Value for Unified Meter and A/C Amp

INFOID:000000002956919

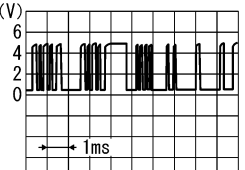
| Terminal No. | Wire color | Item   | Condition       |  | Reference value (Approx.)   |
|--------------|------------|--|-----------------|--|---|
|              |            |  | Ignition switch | Operation or condition                               |   |
| 7            | R          | TX communication line (To combination meter) | ON              | —  |  <p style="text-align: right; font-size: small;">SKIA3362E</p> |
| 9            | W/L        | Seat belt buckle switch (drive side)         | ON              | Seat belt is unfastened (Seat belt buckle switch ON) | 0 V   |
|              |            |  |                 | Seat belt is fastened (Seat belt buckle switch OFF)  | 12 V  |

# WARNING CHIME

## < SERVICE INFORMATION >

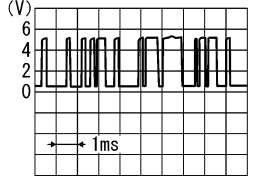
| Terminal No. | Wire color | Item  | Condition       |                        | Reference value (Approx.)  |
|--------------|------------|---|-----------------|------------------------|--|
|              |            |   | Ignition switch | Operation or condition |  |
| 27           | G          | RX communication line<br>(From combination meter) | ON              | —                      | <br>SKIA3361E |
| 53           | W/G        | Ignition switch ON or START                       | ON              | —                      | Battery voltage  |
| 54           | W/G        | Battery power supply                              | OFF             | —                      | Battery voltage  |
| 55           | B          | Ground  | ON              | —                      | 0 V  |
| 56           | L          | CAN-H   | —               | —                      | —  |
| 71           | B          | Ground (Power)                                    | ON              | —                      | 0 V  |
| 72           | P          | CAN-L   | —               | —                      | —  |

## Terminal and Reference Value for BCM

INFOID:000000002956920

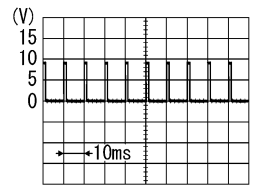
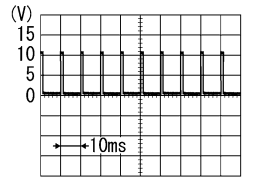
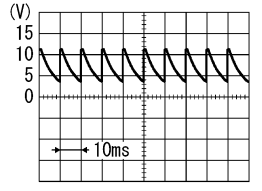
| Terminal No. | Wire color | Item                        | Condition       |  | Reference value (Approx.)  |
|--------------|------------|-----------------------------|-----------------|--|--|
|              |            |                             | Ignition switch | Operation or condition                                     |  |
| 2            | L/R        | Combination switch input 5  | ON              | Lighting switch is 1ST position<br>(Wiper dial position 4) | <br>PKIB4957J |
|              |            |                             |                 | Lighting switch is OFF position                            | 0 V  |
| 33           | GR         | Combination switch output 4 | ON              | Lighting switch is 1ST position<br>(Wiper dial position 4) | <br>PKIB4958J |
|              |            |                             |                 | Lighting switch is OFF position                            | <br>PKIB4960J |
| 37           | LG         | Key switch signal           | OFF             | Intelligent Key is inserted into key slot                  | 12 V   |
|              |            |                             |                 | Intelligent Key is removed from key slot                   | 0 V  |
| 38           | W          | Ignition switch ON or START | ON              | —  | Battery voltage  |
| 39           | L          | CAN-H                       | —               | —  | —  |

# WARNING CHIME

## < SERVICE INFORMATION >

| Terminal No. | Wire color | Item                            | Condition       |   | Reference value (Approx.) |
|--------------|------------|---------------------------------|-----------------|---|---------------------------|
|              |            |                                 | Ignition switch | Operation or condition                            |                           |
| 40           | P          | CAN-L                           | —               | —   | —                         |
| 42           | P          | Battery power supply            | OFF             | —   | Battery voltage           |
| 52           | B          | Ground                          | ON              | —   | 0 V                       |
| 55           | W          | Battery power supply            | OFF             | —   | Battery voltage           |
| 62           | V          | Front door switch (driver side) | OFF             | When driver side door is opened (Door switch ON)  | 0 V                       |
|              |            |                                 |                 | When driver side door is closed (Door switch OFF) | 12 V                      |

## CONSULT-III Function (BCM)

INFOID:000000002956921

CONSULT-III can display each diagnostic item using the diagnostic test modes shown following.

| System | Test item | Diagnosis mode         | Description   |
|--------|-----------|------------------------|---|
| BCM    | BUZZER    | Data Monitor           | Displays BCM input data in real time.   |
|        |           | Active Test            | Operation of electrical loads can be checked by sending driving signal to them. |
|        | BCM       | Self Diagnostic Result | BCM performs self-diagnosis of CAN communication.                               |

## DATA MONITOR

### Display Item List

x: Applicable

| Display item [Unit]   | ALL SIGNALS | SELECTION FROM MENU | Description   |
|-----------------------|-------------|---------------------|---|
| IGN ON SW [On/Off]    | X           | X                   | Displays [On/Off] condition of ignition switch.                       |
| KEY ON SW [On/Off]    | X           | X                   | Displays [On/Off] condition of key switch.                            |
| DOOR SW-DR [On/Off]   | X           | X                   | Displays [On/Off] condition of front door switch (driver side).       |
| TAIL LAMP SW [On/Off] | X           | X                   | Displays [On/Off] condition of lighting switch.                       |
| FR FOG SW [On/Off]    | X           | X                   | Displays [On/Off] condition of front fog lamp switch.                 |
| BUCKLE SW [On/Off]    | X           | X                   | Displays [On/Off] condition of seat belt buckle switch (driver side). |

## ACTIVE TEST

### Display Item List

| Display item        | Description   |
|---------------------|---|
| LIGHT WARN ALM      | This test is able to check light warning chime operation.     |
| IGN KEY WARN ALM    | This test is able to check key warning chime operation.       |
| SEAT BELT WARN TEST | This test is able to check seat belt warning chime operation. |

## SELF-DIAG RESULTS

### Display Item List

| Display item [Code]       | Malfunction is detected when...               |
|---------------------------|---|
| CAN communication [U1000] | Malfunction is detected in CAN communication. |

### NOTE:

If "CAN communication [U1000]" is indicated, after printing the monitor item, go to "LAN system". Refer to [LAN-29. "CAN System Specification Chart"](#).

## CONSULT-III Function (METER/M&A)

INFOID:000000003302855

Refer to [DI-27. "CONSULT-III Function \(METER/M&A\)"](#) in "UNIFIED METER AND A/C AMP".

# WARNING CHIME

< SERVICE INFORMATION >

## Trouble Diagnosis

INFOID:000000002956923

### HOW TO PERFORM TROUBLE DIAGNOSIS

1. Confirm the symptom and customer complaint.
2. Understand the outline of system. Refer to [DI-54, "System Description"](#).
3. Perform the preliminary inspection. Refer to "PRELIMINARY INSPECTION".
4. Referring to trouble diagnosis chart, make sure the cause of the malfunction and repair or replace applicable parts. Refer to "SYMPTOM CHART".
5. Does warning chime system operate normally? If yes, GO TO 6. If no, GO TO 3.
6. INSPECTION END

### PRELIMINARY INSPECTION

#### 1.CHECK BCM (CONSULT-III)

Perform self-diagnosis of BCM. Refer to [BCS-11, "CONSULT-III Function \(BCM\)"](#).

##### Self-diagnostic results content

No malfunction detected>> GO TO 2.

Malfunction detected>> Check applicable parts, and repair or replace corresponding parts.

#### 2.CHECK UNIFIED METER AND A/C AMP. (CONSULT-III)

Perform self-diagnosis of unified meter and A/C amp. Refer to [DI-27, "CONSULT-III Function \(METER/M&A\)"](#).

##### Self-diagnostic results content

No malfunction detected>> INSPECTION END

Malfunction detected>> Check applicable parts, and repair or replace corresponding parts.

### SYMPTOM CHART

| Symptom  | Diagnosis/Service procedure  |
|--|--|
| All warning chime systems do not activate.             | Perform <a href="#">DI-64, "Meter Buzzer Circuit Inspection"</a> .   |
| Light warning chime does not activate.                 | Perform the following inspections.<br>1. <a href="#">DI-65, "Lighting Switch Signal Inspection"</a><br>2. <a href="#">DI-65, "Front Door Switch (Driver Side) Signal Inspection"</a><br>Replace BCM, found normal function in the above inspections. |
| Seat belt warning chime does not activate.             | Perform <a href="#">DI-66, "Seat Belt Buckle Switch Signal Inspection"</a> .<br>Replace BCM, found normal function in the above inspection.  |
| Parking brake release warning chime does not activate. | Perform <a href="#">DI-67, "Parking Brake Switch Signal Inspection"</a> .<br>Replace combination meter, found normal function in the above inspection.   |

### Meter Buzzer Circuit Inspection

INFOID:000000002956924

#### 1.CHECK BATTERY POWER SUPPLY OF COMBINATION METER

Check battery power supply of combination meter. Refer to [DI-19, "Power Supply and Ground Circuit Inspection"](#) in combination meter.

##### OK or NG

OK >> GO TO 2.

NG >> Repair battery power supply circuit of combination meter.

#### 2.CHECK UNIFIED METER AND A/C AMP. INPUT SIGNAL

1. Select "METER/M&A" on CONSULT-III.
2. With "Data Monitor", confirm "BUZZER" under the condition of buzzer input. (Seat belt warning chime, turn signal lamp operate, etc.)

**"BUZZER"**



# WARNING CHIME

## < SERVICE INFORMATION >

- Under the condition of buzzer input : On**  
**Except above : Off**

### OK or NG

- OK >> GO TO 3.  
 NG >> Replace BCM. Refer to [BCS-14, "Removal and Installation of BCM"](#).

## 3.REPLACE COMBINATION METER

Replace combination meter.

### Does meter buzzer beep?

- YES >> INSPECTION END  
 NO >> Replace unified meter and A/C map.

## Lighting Switch Signal Inspection

INFOID:000000002956925

### 1.CHECK BCM INPUT SIGNAL

- Select "BCM" on CONSULT-III.
- With "Data Monitor" of "BUZZER", confirm "TAIL LAMP SW" when the lighting switch is operated.

#### "TAIL LAMP SW"

- Lighting switch ON (1st position) : On**  
**Lighting switch OFF : Off**

### OK or NG

- OK >> Lighting switch signal is OK. Return to [DI-64, "Trouble Diagnosis"](#).  
 NG >> Check the lighting switch. Refer to [LT-195, "Switch Circuit Inspection"](#).

## Front Door Switch (Driver Side) Signal Inspection

INFOID:000000002956926

### 1.CHECK BCM INPUT SIGNAL

#### With CONSULT-III

- Select "BCM" on CONSULT-III.
- With "Data Monitor" of "BUZZER", confirm "DOOR SW-DR" when the driver side door is opened/closed.

#### "DOOR SW-DR"

- When driver side door is opened : On**  
**When driver side door is closed : Off**

#### Without CONSULT-III

Check voltage between BCM harness connector and ground.

| Terminals     |          | Condition         | Voltage (Approx.) |
|---------------|----------|-------------------|-------------------|
| (+)           | (-)      |                   |                   |
| BCM connector | Terminal | Driver side door: |                   |
| M3            | 62       | Open              | 0 V               |
|               |          | Close             | 12 V              |

### OK or NG

- OK >> Front door switch (driver side) signal is OK. Return to [DI-64, "Trouble Diagnosis"](#).  
 NG >> GO TO 2.

## 2.CHECK FRONT DOOR SWITCH (DRIVER SIDE) CIRCUIT

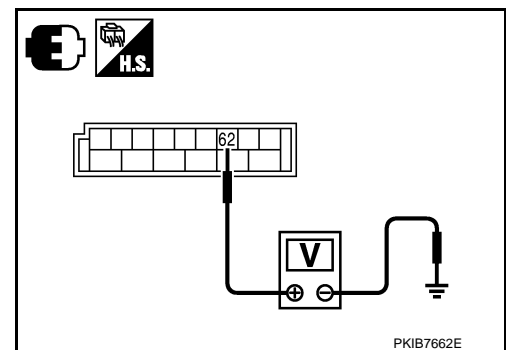

# WARNING CHIME

## < SERVICE INFORMATION >

1. Turn ignition switch OFF.
2. Disconnect BCM connector and front door switch (driver side) connector.
3. Check continuity between BCM harness connector (A) and front door switch (driver side) harness connector (B).

| A         |          | B         |          | Continuity |
|-----------|----------|-----------|----------|------------|
| Connector | Terminal | Connector | Terminal |            |
| M3        | 62       | B11       | 2        | Yes        |

4. Check continuity between BCM harness connector (A) and ground.

| A         |          | Ground | Continuity |
|-----------|----------|--------|------------|
| Connector | Terminal |        |            |
| M3        | 62       |        | No         |

### OK or NG

- OK >> GO TO 3.  
 NG >> Repair harness or connector.

## 3. CHECK FRONT DOOR SWITCH (DRIVER SIDE)

Check front door switch (driver side). Refer to [DI-68, "Electrical Component Inspection"](#).

### OK or NG

- OK >> Replace BCM. Refer to [BCS-14, "Removal and Installation of BCM"](#).  
 NG >> Replace front door switch (driver side).

## Seat Belt Buckle Switch Signal Inspection

INFOID:000000002956927

### 1. CHECK BCM INPUT SIGNAL

1. Select "BCM" on CONSULT-III.
2. With "Data Monitor" of "BUZZER", confirm "BUCKLE SW" when the seat belt is fastened/unfastened.

#### "BUCKLE SW"

- When seat belt is fastened : Off  
 When seat belt is unfastened : On

### OK or NG

- OK >> Seat belt buckle switch signal is OK. Return to [DI-64, "Trouble Diagnosis"](#).  
 NG >> GO TO 2.

### 2. CHECK UNIFIED METER AND A/C AMP. INPUT SIGNAL

1. Turn ignition switch ON.
2. Check voltage between unified meter and A/C amp. harness connector and ground.

| Terminals                            |          | Condition                | Voltage (Approx.) |
|--------------------------------------|----------|--------------------------|-------------------|
| (+)                                  |          |                          |                   |
| Unified meter and A/C amp. connector | Terminal | Seat belt (driver side): |                   |
| M64                                  | 9        | Fasten                   | 12 V              |
|                                      |          | Unfasten                 | 0 V               |

### OK or NG

- OK >> Replace unified meter and A/C amp.  
 NG >> GO TO 3.

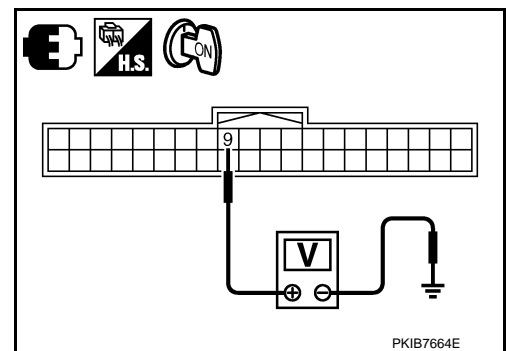
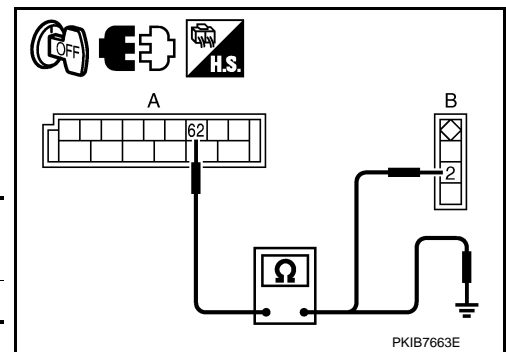

# WARNING CHIME

## < SERVICE INFORMATION >

### 3. CHECK SEAT BELT BUCKLE SWITCH CIRCUIT

1. Turn ignition switch OFF.
2. Disconnect unified meter and A/C amp. connector and seat belt buckle switch (driver side) connector.
3. Check continuity between unified meter and A/C amp. harness connector (A) and seat belt buckle switch (driver side) harness connector (B).

| A         |          | B         |          | Continuity |
|-----------|----------|-----------|----------|------------|
| Connector | Terminal | Connector | Terminal |            |
| M64       | 9        | B203      | 1        | Yes        |

4. Check harness continuity between unified meter and A/C amp. harness connector (A) and ground.

| A         |          | Ground | Continuity |
|-----------|----------|--------|------------|
| Connector | Terminal |        |            |
| M64       | 9        |        | No         |

#### OK or NG

- OK >> GO TO 4.  
NG >> Repair harness or connector.

### 4. CHECK SEAT BELT BUCKLE SWITCH (DRIVER SIDE)

Check seat belt buckle switch (driver side). Refer to [DI-68, "Electrical Component Inspection"](#).

#### OK or NG

- OK >> Check seat belt buckle switch (driver side) ground circuit.  
NG >> Replace seat belt buckle switch (driver side).

## Parking Brake Switch Signal Inspection

INFOID:000000003300870

### 1. CHECK PARKING BRAKE WARNING LAMP

1. Start the engine.
2. Check the operation of the brake warning lamp by operating the parking brake.

**Parking brake applied :**           **On**  
**Parking brake released :**       **Off**

#### OK or NG

- OK >> Parking brake switch signal circuit is OK. Return to [DI-64, "Trouble Diagnosis"](#).  
NG >> GO TO 2.

### 2. CHECK COMBINATION METER INPUT SIGNAL

1. Check the voltage and waveform between combination meter harness connector and ground.

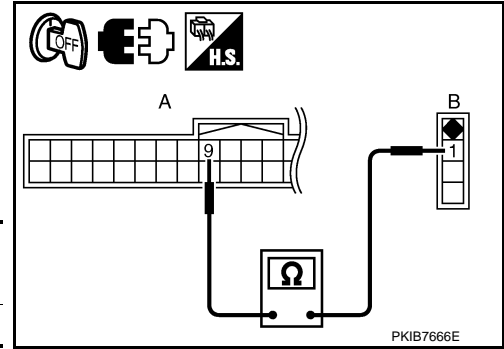

A  
B  
C  
D  
E  
F  
G  
H  
I  
J  
DI  
L  
M  
N  
O  
P

# WARNING CHIME

## < SERVICE INFORMATION >

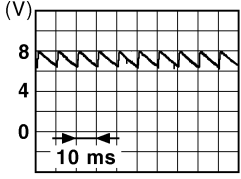
| Terminals                   |          | Condition     | Voltage (Approx.)   |
|-----------------------------|----------|---------------|---|
| (+)                         | (-)      |               |   |
| Combination meter connector | Terminal | Parking brake |   |
|                             |          | Applied       | 0 V   |
| M52                         | 5        | Released      |  |

JSNIA0007GB

### OK or NG

- OK >> Replace the combination meter.
- NG >> GO TO 3.

### **3.**CHECK PARKING BRAKE SWITCH SIGNAL CIRCUIT

1. Turn the ignition switch OFF.
2. Disconnect combination meter connector and parking brake switch connector.
3. Check continuity between combination meter harness connector and parking brake switch harness connector.

| Combination meter connector |          | Parking brake switch connector |          | Continuity |
|-----------------------------|----------|--------------------------------|----------|------------|
| Connector                   | Terminal | Connector                      | Terminal |            |
| M52                         | 5        | E107                           | 1        | Yes        |

4. Check continuity between combination meter harness connector and ground.

| Combination meter connector |          | Ground | Continuity |
|-----------------------------|----------|--------|------------|
| Connector                   | Terminal |        |            |
| M52                         | 5        |        | No         |

### OK or NG

- OK >> GO TO 4.
- NG >> Repair harness connector or connector.

### **4.**CHECK PARKING BRAKE SWITCH CIRCUIT

1. Check the parking brake switch circuit. Refer to [BRC-53, "Parking Brake Switch Circuit"](#).

### OK or NG

- OK >> Replace the combination meter.
- NG >> Replace the parking brake switch. Refer to [PB-4, "Component"](#).

## Electrical Component Inspection

INFOID:000000002956928

### FRONT DOOR SWITCH (DRIVER SIDE)

# WARNING CHIME

## < SERVICE INFORMATION >

Check continuity between terminal 2 and door switch case ground.

| Terminal |                         | Condition                     | Continuity |
|----------|-------------------------|-------------------------------|------------|
| 2        | Door switch case ground | When door switch is released. | Yes        |
|          |                         | When door switch is pushed.   | No         |

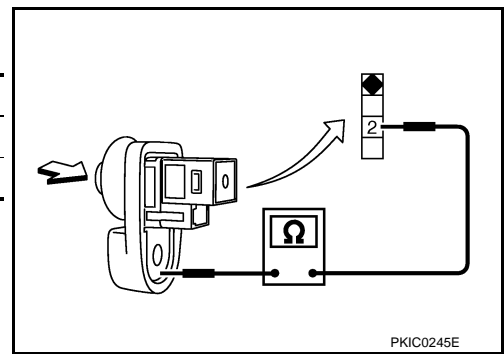

## SEAT BELT BUCKLE SWITCH (DRIVER SIDE)

Check continuity between terminals 1 and 2.

| Terminal |   | Condition                     | Continuity |
|----------|---|-------------------------------|------------|
| 1        | 2 | When seat belt is unfastened. | Yes        |
|          |   | When seat belt is fastened.   | No         |

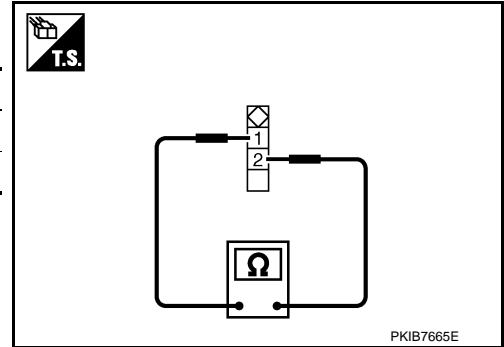

A  
B  
C  
D  
E  
F  
G  
H  
I  
J  
DI  
L  
M  
N  
O  
P

DI

# LANE DEPARTURE WARNING SYSTEM

< SERVICE INFORMATION >

---

## LANE DEPARTURE WARNING SYSTEM

### Description

INFOID:000000003077173

Regarding the information for Lane Departure Warning (LDW), refer to Lane Departure Prevention (LDP) system [ACS-87. "System Description"](#).

# COMPASS

< SERVICE INFORMATION >

## COMPASS

### Precaution for Compass

INFOID:000000002956953

#### NOTE:

- Do not install the ski rack, antenna, etc. which is attach to the vehicle with a magnet base. It affects the operation of the compass.
- When cleaning the mirror, use a paper towel or similar material dampened with glass cleaner. Do not spray glass cleaner directly on the mirror as it may cause the liquid cleaner to enter the mirror housing.

### System Description

INFOID:000000002956954

- This electronic compass is able to display 8 primary directions: N, NE, E, SE, S, SW, W, NW.
- The compass switch (1) is used to operate the compass.

(1) : Compass switch

(2) : Compass display

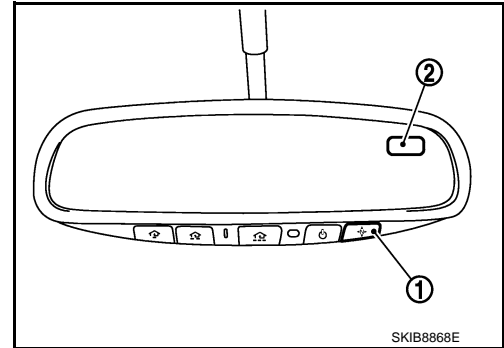

#### Switch Operation

|                                       |   |
|---------------------------------------|---|
| Press                                 | Compass is turned ON/OFF                            |
| Press and hold (for 3 – 9 sec.)       | Compass display turns to zone variation change mode |
| Press and hold (for more than 9 sec.) | Compass display turns to calibration mode           |

- All standard compasses determine direction relative to Magnetic North; however, this electronic compass is designed to display direction relative to True North.
- The difference between Magnetic North and True North varies from place to place across the surface of the earth.
- This electronic compass must be “told” approximately where it is on the earth’s surface so that the Magnetic North reading can be properly converted into a True North display.
- To tell the electronic compass where it’s at, the earth is separated into numbered “Zone Variances”. The Zone Variance number in which the compass is to function must be entered into this electronic compass.
- Each zone is magnetically about 4.2° wide. Typically, anything under 22.5° total zone change is not noticed on the electronic compass display. However, over 22.5°, a reading may be off by one or more primary directions.
- On long trips, a vehicle may leave its original zone and enter one or more new zones. Generally, you do not need to reset the compass zone if you travel between 3 or 4 zones, such as business travel or vacation. The typical driver will not notice any difference on the display within 3 or 4 zones. However, if the vehicle is “permanently” moved to a new location, it is recommended that the compass zone be reset.

### Troubleshooting

INFOID:000000002956955

- The electronic compass is highly protected from changes in most magnetic fields. However, some large changes in magnetic fields can affect it. Some examples are (but not limited to): high tension power lines, large steel buildings, subways, steel bridges, automatic car washes, large piles of scrap metal, etc. While this does not happen very often, it is possible.
- During normal operation, the Compass Mirror will continuously update the compass calibration to adjust for gradual changes in the vehicle's magnetic “remnant” field. If the vehicle is subjected to high magnetic influences, the compass may appear to indicate false headings, become locked, or appear that it is unable to be calibrated. If this occurs, perform the calibration procedure.
- If at any time the compass continually displays the incorrect direction or the reading is erratic or locked, verify the correct zone variance.

# COMPASS

## < SERVICE INFORMATION >

### Troubleshooting Chart

| Symptom   | Cause  | Solution / Reference   |
|---|--|--|
| The compass display reads "C".                                    | <ul style="list-style-type: none"> <li>Compass is not calibrated.</li> <li>Incorrect zone variance setting.</li> <li>Large change in magnetic field (Steel bridges, subways, concentrations of metal, carwashes, etc.)</li> <li>Compass was calibrated incorrectly or in the presence of a strong magnetic field.</li> </ul> | Perform Calibration.<br>Refer to <a href="#">DI-72, "Calibration Procedure"</a> .  |
| Compass shows the wrong direction.                                |  |  |
| Compass does not change direction – appears "Locked".             |  |  |
| Compass does not show all the directions, one or more is missing. |  |  |
| The compass was calibrated but it "loses" calibration.            |  |  |
| On long trips the compass shows the wrong direction.              |  | Perform Zone Variation Setting if correct reading is desired in that location.<br>Refer to <a href="#">DI-72, "Zone Variation Setting Procedure"</a> . |
| Compass does not work – No direction is displayed.                | Compass not turned ON.   | Check for green LED indicator (inside mirror switch).  |
|   | No power to inside mirror.   | Check power supply circuit.  |

## Zone Variation Setting Procedure

INFOID:000000002956956

### NOTE:

The zone setting is factory preset ("default" setting) to zone 8.

1. Press and hold the compass switch for 3 – 9 seconds.
2. The current zone setting appears on the compass display.
3. Find the current geographical location number in the Zone Variation Chart.
4. Select the new zone number. (Press the compass switch until the new zone number appears on the compass display.)
5. After select the new zone number, the compass display will automatically shows a direction within a few seconds.
6. Perform the following Calibration Procedure for more accurate indications.

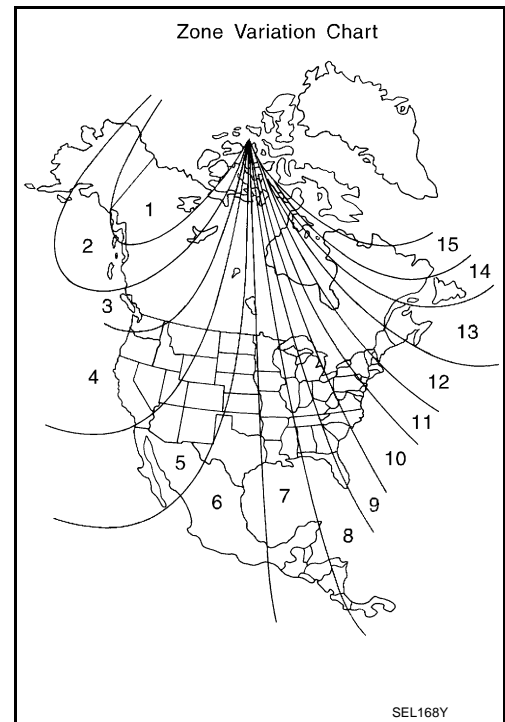

## Calibration Procedure

INFOID:000000002956957

### NOTE:

The compass calibrates itself under normal driving conditions. However, occasional circumstances may cause the compass to operate inaccurately. Example: Driving from rural (wide open) areas to crowded city areas, or if an aftermarket (i.e., non original equipment) antenna with a magnetic base is attached to the vehicle. Calibrate the mirror compass if the display shows only one direction or a limited number of directions.

### NOTE:

- If "magnetic hats" are used in the dealership for vehicle identification, remove the hat from the vehicle before performing the following steps. Do NOT put the hat back on the vehicle after the procedure is completed.
- Drive the vehicle to an open level area; away from large metallic objects, structures, and overhead power lines.



# COMPASS

## < SERVICE INFORMATION >

- Turn off “non-essential” electrical accessories (rear window defrost, heater/air conditioning, wipers) and close the doors.
- 1. Verify the correct compass zone setting for the geographical location. Refer to [DI-72. "Zone Variation Setting Procedure"](#).
- 2. Press and hold the compass switch for more than 9 seconds.
- 3. “C” is displayed on the compass display, when calibration starts.
- 4. Drive slowly [less than 8 km/h (5 mph)] in a circle until the “C / CAL” is replaced with primary headings (N, NE, E, SE, S, SW, W, or NW).  
**NOTE:**  
This will require driving at least 2 complete 360 degree circles; 3 complete circles may be required.
- 5. The compass calibration procedure is now complete. The compass should operate normally.  
**NOTE:**  
If at any time the compass continually displays the incorrect direction or the reading is erratic or locked, repeat the calibration procedure.

A  
B  
C  
D  
E  
F  
G  
H  
I  
J  
DI  
L  
M  
N  
O  
P

# COMPASS

< SERVICE INFORMATION >

## Wiring Diagram - COMPAS -

INFOID:000000002956958

### DI-COMPAS-01

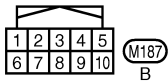
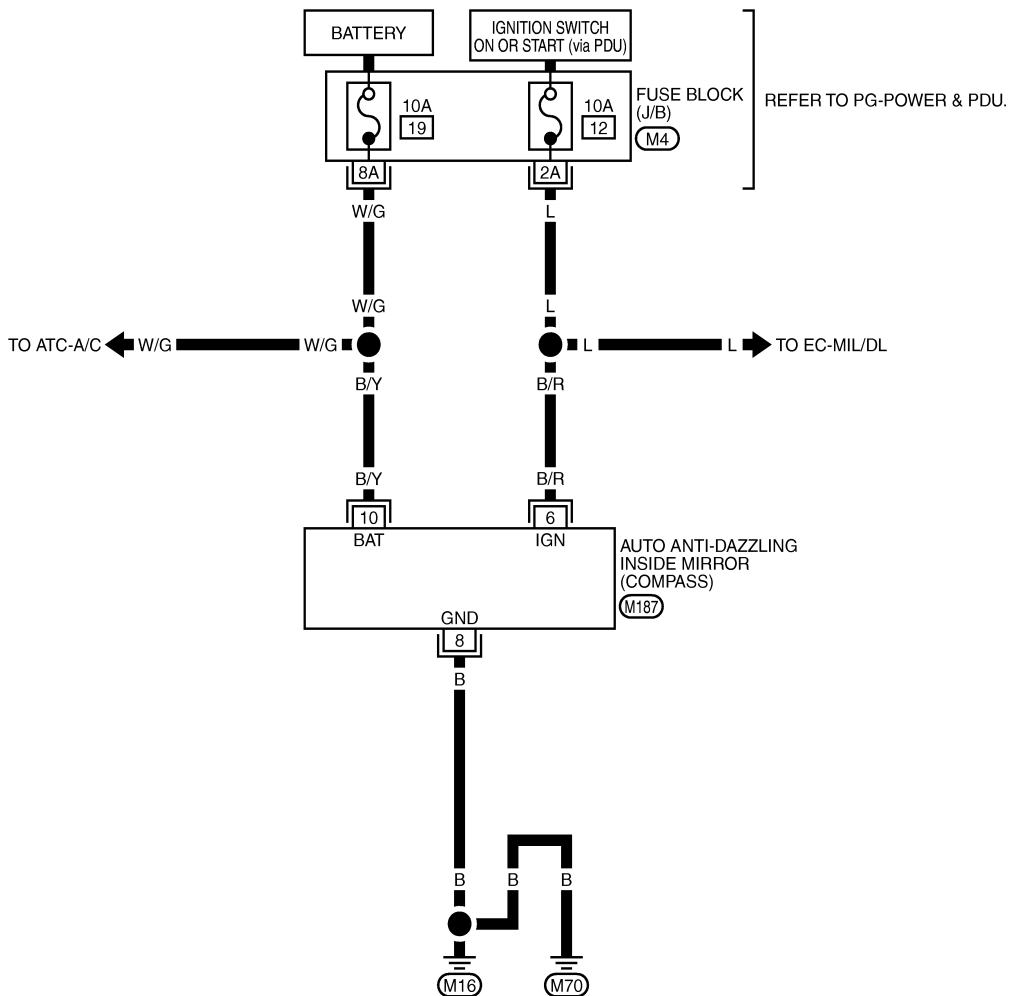

REFER TO THE FOLLOWING.  
 (M4) - FUSE BLOCK - JUNCTION BOX (J/B)

TKWT6869E

## Removal and Installation of Compass

Refer to [GW-62](#).

INFOID:000000002956959

# CLOCK

< SERVICE INFORMATION >

## CLOCK

### Wiring Diagram - CLOCK -

INFOID:000000002956960

#### DI-CLOCK-01

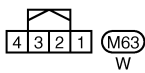
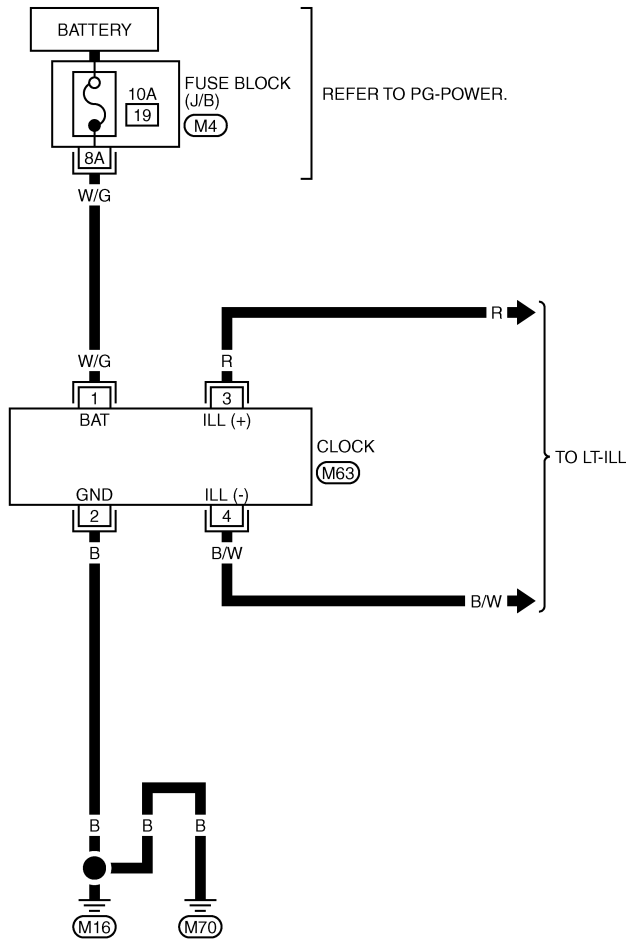

REFER TO THE FOLLOWING.  
 (M4) - FUSE BLOCK-JUNCTION BOX (J/B)

TKWT5289E

### Removal and Installation of Clock

INFOID:000000002956961

#### REMOVAL

A  
B  
C  
D  
E  
F  
G  
H  
I  
J  
DI  
L  
M  
N  
O  
P

## CLOCK

### < SERVICE INFORMATION >

1. Remove cluster lid C (1). Refer to [IP-18, "CLUSTER LID C : Component Parts Location"](#).
2. Remove preset switch. Refer to [AV-494, "Removal and Installation"](#) (Without mobile entertainment system) or [AV-1078, "Removal and Installation"](#) (With mobile entertainment system).
3. Disengage tabs, and remove clock (2) from cluster lid C (1).

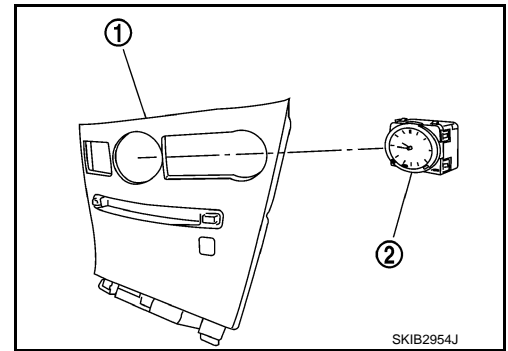

### INSTALLATION

Installation is the reverse order of removal.

# CAN COMMUNICATION

< SERVICE INFORMATION >

## CAN COMMUNICATION

---

### System Description

INFOID:000000002956962

CAN (Controller Area Network) is a serial communication line for real time application. It is an on-vehicle multiplex communication line with high data communication speed and excellent error detection ability. Many electronic control units are equipped onto a vehicle, and each control unit shares information and links with other control units during operation (not independent). In CAN communication, control units are connected with 2 communication lines (CAN H line, CAN L line) allowing a high rate of information transmission with less wiring. Each control unit transmits/receives data but selectively reads required data only.

### CAN Communication Unit

INFOID:000000002956963

Refer to [LAN-30, "CAN Communication Signal Chart"](#) in "LAN SYSTEM".

A  
B  
C  
D  
E  
F  
G  
H  
I  
J  
DI  
L  
M  
N  
O  
P

